

INDEX

List of categories by title and page numbers

(1 - 12) Aircraft Components and Accessories	(13 - 14) Ammunition and Explosives	(15 - 16) Bearings
(17 - 23) Chemicals	(24 - 26) Cleaning Equipment and Supplies	(27 - 29) Clothing
(30 - 32) Communication Equipment	(33 - 136) Electrical	(137 - 139) Engine Accessories
(140 - 140) Engines, Turbines, and Components	(141 - 142) Fiber Optics	(143 - 143) Furniture
(144 - 146) Ground Handling and Servicing Equipment	(147 - 161) Hand Tools	(162 - 233) Hardware and Abrasives
(234 - 251) Instruments	(252 - 258) Lighting Fixtures and Lamps	(259 - 265) Maintenance and Repair Shop Equipment
(266 - 267) Materials Handling Equipment	(268 - 268) Measuring Tools	(269 - 270) Mechanical Power Transmission Equipment
(271 - 272) Medical Supplies	(273 - 273) Miscellaneous	(274 - 277) Nonmetallic Fabricated Materials
(278 - 277) Office Supplies	(278 - 279) Ordinance Hardware	(280 - 292) Pipe, Tubing, Hose, and Fittings
(293 - 294) Plumbing and Heating	(295 - 296) Pumps and Compressors	(297 - 299) Refrigeration and Air Conditioning
(300 - 302) Rope, Cable, Chain, and Fittings	(303 - 304) Safety Equipment	(305 - 344) Sealers and Adhesives
(345 - 345) Ship and Marine Equipment	(346 - 352) Structural Components	(353 - 354) Structures and Scaffolding
(355 - 355) Textiles	(356 - 362) Valves	(363 - 367) Vehicular Equipment Components
(368 - 373) Weapons		

1680-01-100-1746

Aircraft Seat Cushion

MISCELLANEOUS AIRCRAFT ACCESSORIES AND COMPONENTS NATIONAL STOCK NUMBER 1680-01-100-1746 CUSHION,SEAT,AIRCRAFT.

Weight and Dimensions

National Stock Number

Box Weight	Box Size	Item Weight	Item Dimensions	FSC	FSG	NIIN	INC
--	--	--	--	1680	16	01-100-1746 / 011001746	32415

National Motor Freight / Schedule B

NMFC	Description	Schedule B
011790	AIRCRAFT PARTS	8803300060 / Other parts of airplanes or helicopters for use in military aircraft (excludes propellers, rotors, undercarriages, and parts thereof)

1168844-3

Adjustable T Spacer

AIRCRAFT LANDING GEAR COMPONENTS NATIONAL STOCK NUMBER 1620-01-164-5791 SPACER,ADJUSTABLE T.

Weight and Dimensions

National Stock Number

Box Weight	Box Size	Item Weight	Item Dimensions	FSC	FSG	NIIN	INC
.2lbs	--	--	--	1620	16	01-164-5791 / 011645791	7777

National Motor Freight / Schedule B

NMFC	Description	Schedule B
106940	SPACERS/SEPARATORS I/S TUBULAR	8803200060 / Undercarriages and parts thereof, for use in military aircraft

16F8415-809

A Fault-function Indicator Panel

END ITEM IDENTIFICATION:

F-16,ACFT

SUPPLEMENTARY FEATURES:

MFR NAME:PANEL-ASSY-NUCLEAR CONSENT/SECURE VOICE

Weight and Dimensions

National Stock Number

Box Weight	Box Size	Item Weight	Item Dimensions	FSC	FSG	NIIN	INC
A999.9lbs	9999 X 9999 X 9999	--	--	1680	16	01-472-6990 / 014726990	61981

National Motor Freight / Schedule B

NMFC	Description	Schedule B
011790	AIRCRAFT PARTS	8803300060 / Other parts of airplanes or helicopters for use in military aircraft (excludes propellers, rotors, undercarriages, and parts thereof)

68F217-30

Multi-loop Line

GENERAL CHARACTERISTICS ITEM DESCRIPTION:

NYLON WEBBING,1.750 IN. WD. O/A,6 PLY,3 LOOPS PER PIN,67500 POUNDS TEST LOAD,60 FT. FINISHED LENGTH

Weight and Dimensions

National Stock Number

Box Weight	Box Size	Item Weight	Item Dimensions	FSC	FSG	NIIN	INC
--		--	--	1670	16	01-062-6313 / 010626313	7777

National Motor Freight / Schedule B

NMFC	Description	Schedule B
053390	CORD/CORDAGE/ROPE/ETC	8803300060 / Other parts of airplanes or helicopters for use in military aircraft (excludes propellers, rotors, undercarriages, and parts thereof)

68F217-49

Multi-loop Line

GENERAL CHARACTERISTICS ITEM DESCRIPTION:

NYLON WEBBING,1.750 IN. WD. O/A,4 PLY,2 LOOPS PER PIN,44500 POUNDS TEST LOAD,9 FT. FINISHED LENGTH

National Motor Freight / Schedule B

National Stock Number

NMFC	Description	Schedule B	FSC	FSG	NIIN	INC
053390	CORD/CORDAGE/ROPE/ETC	8803300060 / Other parts of airplanes or helicopters for use in military aircraft (excludes propellers, rotors, undercarriages, and parts thereof)	1670	16	01-062-6304 / 010626304	7777

68F217-59

Multi-loop Line

GENERAL CHARACTERISTICS ITEM DESCRIPTION:

NYLON WEBBING,1.750 IN. WD. O/A,8 PLY,4 LOOPS PER PIN,89000 POUNDS TEST LOAD,11 FT. FINISHED LENGTH

Weight and Dimensions

National Stock Number

Box Weight	Box Size	Item Weight	Item Dimensions	FSC	FSG	NIIN	INC
--		--	--	1670	16	01-062-6310 / 010626310	7777

National Motor Freight / Schedule B

NMFC	Description	Schedule B
053390	CORD/CORDAGE/ROPE/ETC	8803300060 / Other parts of airplanes or helicopters for use in military aircraft (excludes propellers, rotors, undercarriages, and parts thereof)

209-070-704-3

Seat Cushion Assy

MISCELLANEOUS AIRCRAFT ACCESSORIES AND COMPONENTS NATIONAL STOCK NUMBER 1680-00-140-7459 CUSHION ASSY,SEAT.

Weight and Dimensions

National Stock Number

Box Weight	Box Size	Item Weight	Item Dimensions	FSC	FSG	NIIN	INC
3.6lbs	--	--	--	1680	16	00-140-7459 / 001407459	77777

National Motor Freight / Schedule B

NMFC	Description	Schedule B
011790	AIRCRAFT PARTS	8803300060 / Other parts of airplanes or helicopters for use in military aircraft (excludes propellers, rotors, undercarriages, and parts thereof)

1680-01-105-1677

Troop And Gunner Skirt Assembly

SPECIAL FEATURES:

NHA 1680-01-435-4739

Weight and Dimensions

National Stock Number

Box Weight	Box Size	Item Weight	Item Dimensions	FSC	FSG	NIIN	INC
.1lbs	--	--	--	1680	16	01-105-1677 / 011051677	7777

National Motor Freight / Schedule B

NMFC	Description	Schedule B
012340	AIRCRAFT:SEATS,CREW	

70500-02161-043

Aircraft Seat Cushion Cover

DESIGN TYPE:

SEAT CUSHION

Weight and Dimensions

National Stock Number

Box Weight	Box Size	Item Weight	Item Dimensions	FSC	FSG	NIIN	INC
4.0lbs	--	--	--	1680	16	01-113-8182 / 011138182	33657

National Motor Freight / Schedule B

NMFC	Description	Schedule B
049170	CLOTH COTTON R SYNTHETIC FIBRE	8803300060 / Other parts of airplanes or helicopters for use in military aircraft (excludes propellers, rotors, undercarriages, and parts thereof)

A-A-52197 T2

Parachute Packing Weight

GENERAL CHARACTERISTICS ITEM DESCRIPTION:

CLOTH,COTTON,DUCK; 19.5 IN,MIN 20.25 IN. MAX LG,2.375 IN; W WHEN FILLED

NONDEFINITIVE SPEC/STD DATA:

II TYPE

Weight and Dimensions

National Stock Number

Box Weight	Box Size	Item Weight	Item Dimensions	FSC	FSG	NIIN	INC
.3lbs	--	--	--	1670	16	00-375-9134 / 003759134	20366

National Motor Freight / Schedule B

NMFC	Description	Schedule B
011790	AIRCRAFT PARTS	8804000000 / Parachutes (including dirigible parachutes and paragliders) and rotochutes; parts thereof and accessories thereto

NGA801VL25RR

Ai Adapter Assembly

MISCELLANEOUS AIRCRAFT ACCESSORIES AND COMPONENTS NATIONAL STOCK NUMBER 1680-01-561-8395 ADAPTER ASSEMBLY,AI.

NORTHROP GRUMMAN SYSTEMS

National Stock Number

FSC	FSG	NIIN	INC
1680	16	01-561-8395 / 015618395	77777

10C-0012-0057

Liquid Oxygen Converter Tank

GENERAL CHARACTERISTICS ITEM DESCRIPTION:

USED ON 10C0012-75 CONVERTER

Weight and Dimensions

National Stock Number

Box Weight	Box Size	Item Weight	Item Dimensions	FSC	FSG	NIIN	INC
70.0lbs	273 X 273 X 275	60.0lbs	225 X 225 X 225	1660	16	00-079-4325 / 000794325	61471

National Motor Freight / Schedule B

NMFC	Description	Schedule B
011790	AIRCRAFT PARTS SUB1	8907900060 / Tanks

FE7590-98

Cartridge Actuated Thruster

CARTRIDGE AND PROPELLANT ACTUATED DEVICES AND COMPONENTS NATIONAL STOCK NUMBER 1377-01-211-7212 THRUSTER,CARTRIDGE ACTUATED.

Weight and Dimensions

National Stock Number

Box Weight	Box Size	Item Weight	Item Dimensions	FSC	FSG	NIIN	INC
600.0lbs		--	--	1377	13	01-211-7212 / 012117212	20511

1355-01-087-4789

Torpedo Suspension Band

GROSS WEIGHT: 155.0 SHIPPING CONTAINER POUNDS AND 155.0 PALLET POUNDS

GENERAL CHARACTERISTICS ITEM DESCRIPTION: MK 78 MOD 1; O/A 42.00 IN. LG; 3.00 IN. W; CONSISTS OF 2 SUSPENSION BANDS MK 78 MOD 1 SUBASSEMBLIES NAVSEA DWG 5349589, ONE RELEASE WIRE DWG 1263779-1, TWO RELEASE WIRES DWG 1263779-2, AND TWO SADDLE PLATE PADS DWG 5349585; 1355-T199 DOD CODE; USED ON TORPEDO MK46 MODS 1,2,5

QUANTITY PER SHIPPING CONTAINER: 9

SHIPPING CONTAINER QUANTITY PER PALLET: 1

PACKAGE NOMINAL OVERALL WIDTH AND TYPE: 20.25 INCHES SHIPPING CONTAINER

PACKAGE NOMINAL OVERALL HEIGHT AND TYPE: 13.38 INCHES SHIPPING CONTAINER

PACKAGE NOMINAL OVERALL LENGTH AND TYPE: 48.00 INCHES SHIPPING CONTAINER

National Stock Number

FSC	FSG	NIIN	INC
1355	13	01-087-4789 / 010874789	20705

012-21172-00

Annular Ball Bearing

BORE SHAPE: STRAIGHT
MATERIAL: STEEL CORROSION RESISTING OVERALL
LOAD DIRECTION: RADIAL
LUBRICATION MATERIAL: GREASE
SURFACE FINISH: GROUND

Weight and Dimensions

National Stock Number

Box Weight	Box Size	Item Weight	Item Dimensions	FSC	FSG	NIIN	INC
--	--	--	--	3110	31	01-082-7129 / 010827129	00014

National Motor Freight / Schedule B

NMFC	Description	Schedule B
114820	BEARINGS/BUSHINGS BALL/ROLLER	8482105028 / Angular contact ball bearings

5004461

Thrust Washer Bearing

CENTER HOLE SHAPE STYLE:	ROUND
CORNER SHAPE:	SQUARE ALL CORNERS
CROSS-SECTIONAL SHAPE STYLE:	RECTANGULAR
DIAMETER:	1.5038 INCHES MINIMUM AND 1.5043 INCHES MAXIMUM
MATERIAL:	CARBON OVERALL
OUTSIDE DIAMETER:	2.3780 INCHES MINIMUM AND 2.3785 INCHES MAXIMUM
OVERALL THICKNESS:	0.3840 INCHES MINIMUM AND 0.3880 INCHES MAXIMUM
STYLE DESIGNATOR:	ROUND
SURFACE CONDITION:	GROUND

Weight and Dimensions

National Stock Number

Box Weight	Box Size	Item Weight	Item Dimensions	FSC	FSG	NIIN	INC
.1lbs	--	--	--	3120	31	01-051-1646 / 010511646	13211

National Motor Freight / Schedule B

NMFC	Description	Schedule B
114820	BEARINGS/BUSHINGS BALL/ROLLER	8482105008 / Thrust ball bearings

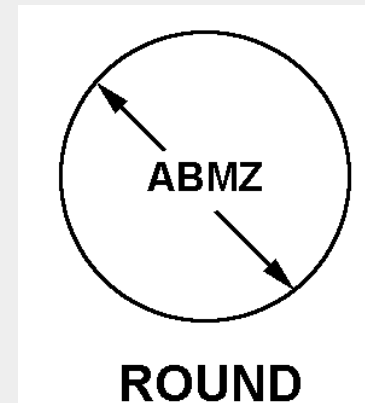

6850-01-392-8439

Solvent Cleaning Compound

BIODEGRADEABLE CHARACTERISTIC: INCLUDED
MATERIAL BASE TYPE: SOLUTION
QUANTITY WITHIN EACH UNIT PACKAGE: 2.5 GALLONS
SPECIAL FEATURES: CONCENTRATED GENERAL PURPOSE CLEANER; MILD ODOR; SAFE ON MOST METALS; USED IN HOT TANK ULTRASONIC AND TURBO WASH SYSTEMS; PACKAGED TWO 2.5 GALLON CONTAINERS PER BOX

Weight and Dimensions

National Stock Number

Box Weight	Box Size	Item Weight	Item Dimensions	FSC	FSG	NIIN	INC
20.0lbs	--	--	--	6850	68	01-392-8439 / 013928439	15627

National Motor Freight / Schedule B

NMFC	Description	Schedule B
050330	COMPOUNDS TYPE CLEANING LIQUID	

6850-01-011-5669

Aircraft Fuel Calibrating Fluid

MAXIMUM VISCOSITY AT RATED TEMP:	1.22 CENTISTOKES AT 77 DEG F
MINIMUM VISCOSITY AT RATED TEMP:	1.12 CENTISTOKES AT 77 DEG F
MINIMUM FLASH POINT:	100.0 DEG FAHRENHEIT
NONDEFINITIVE SPEC/STD DATA:	II TYPE
QUANTITY WITHIN EACH UNIT PACKAGE:	1.0 GALLONS
SPECIFIC GRAVITY AT SPECIFIED TEMP:	0.770 SP GR AT 60 DEG F

Weight and Dimensions

National Stock Number

Box Weight	Box Size	Item Weight	Item Dimensions	FSC	FSG	NIIN	INC
8.0lbs	--	--	--	6850	68	01-011-5669 / 010115669	18456

National Motor Freight / Schedule B

NMFC	Description	Schedule B
043940	CHEMICALS	

132-001

Techni Monobromotrifluoromethane

PHYSICAL FORM:

LIQUID

SPECIAL FEATURES:

DESIGN TYPE - HAND

SUPPLIED AMOUNT:

2.800 POUNDS

Weight and Dimensions

National Stock Number

Box Weight	Box Size	Item Weight	Item Dimensions	FSC	FSG	NIIN	INC
7.8lbs	--	--	--	6830	68	00-555-8837 / 005558837	16851

National Motor Freight / Schedule B

NMFC	Description	Schedule B
069185	FIRE EXTINGUISHERS CHEMICAL	

ENSTRIP GT 317A

Electrodeposit Stripping Compoun

PHYSICAL FORM: LIQUID

SPECIAL FEATURES: TEMPERATURE 70 DEGF TO 90 DEGF; CONTAINS ACIDIC MATERIAL; BOILING POINT 220 DEGF; CONTACT MAY CAUSE BURNS, DAMAGE TO EYES, LUNGS AND RESPIRATORY TRACT

UNABLE TO DECODE: UNABLE TO DECODE

National Stock Number

FSC	FSG	NIIN	INC
6850	68	01-457-6066 / 014576066	13708

ENSTRIP GT 317C

Electrodeposit Stripping Compoun

PHYSICAL FORM: LIQUID
SPECIAL FEATURES: TEMPERATURE 70 DEGF TO 90 DEGF; CONTACT MAY CAUSE BURNS, DAMAGE TO EYES, LUNGS AND RESPIRATORY TRACT
UNABLE TO DECODE: UNABLE TO DECODE

National Stock Number

FSC	FSG	NIIN	INC
6850	68	01-457-6067 / 014576067	13708

660100-10

Activated Desiccant

SPECIAL FEATURES:

10 BAGS PER CAN;

Weight and Dimensions

National Stock Number

Box Weight	Box Size	Item Weight	Item Dimensions	FSC	FSG	NIIN	INC
--	--	--	--	6850	68	01-551-8733 / 015518733	16537

National Motor Freight / Schedule B

NMFC	Description	Schedule B
046050	SILICA GEL/CATALYST	

801-1500-45

Turbidity Standard Solution

COLOR: COLORLESS
QUANTITY WITHIN EACH UNIT PACKAGE: 30.0 MILLILITERS
SPECIAL FEATURES: 30 ML BOTTLE; SOLUBLE; BOING PT 100 DEG C; LIQUID; HI93703-0 PRIM STAND 0 FTU USED FOR TURBILITY MEASUREMENTS
PART NAME ASSIGNED BY CONTROLLING AGENCY: STANDARD CALIBRATION SOL-0 FTU
UNIT PACKAGE QUANTITY: N1

Weight and Dimensions

National Stock Number

Box Weight	Box Size	Item Weight	Item Dimensions	FSC	FSG	NIIN	INC
--		--	--	6850	68	01-600-2118 / 016002118	16718

7910-00-530-6261

Electric Vacuum Cleaner

BLOWER OUTLET:	INCLUDED
DESIGN TYPE:	VERTICAL TANK
FURNISHED ITEMS AND QUANTITY:	FLOOR BRUSH 1; ROUND BRUSH 1; HOSE ASSY 1; CREVICE NOZZLE 1; TAPERED NOZZLE 1; STRAIGHT TUBE 1, SWITCHBOARD BRUSH 1
FREQUENCY IN HERTZ:	60.0
HORSEPOWER RATING:	1.3
NONDEFINITIVE SPEC/STD DATA:	II TYPE
INPUT WATTAGE RATING IN WATTS:	1400.0 MAXIMUM
REVOLVING BRUSH:	NOT INCLUDED
SPECIAL FEATURES:	30 FT POWER CORD; 6 GALLON CAPACITY ELECTRIC WET/DRY VACUUM
PHASE:	SINGLE
VOLTAGE RATING IN VOLTS:	115.0 DC
WATER LIFT DESIGN FEATURE:	INCLUDED

National Motor Freight / Schedule B

National Stock Number

NMFC	Description	Schedule B	FSC	FSG	NIIN	INC
132680	MACHINERY:VACUUM CLEANERS	8508600000 / Vacuum cleaners	7910	79	00-530-6261 / 005306261	28054

5602260

Plastic Polish

CRITICALITY CODE
JUSTIFICATION:

SUPP

SPECIAL FEATURES:

PLASTIC POLISH TYPE II; IDENTIFIED BY USAF CONTROL NUMBER 200925154-03 FOR USE ON F-16 CANOPIES; WHIZ AIRCRAFT CLEANING COMPOUND - 5602260;
CONTACT HILL AFB FOR PRODUCT INQUIRY: 416 SCMS/GUMAE, DSN 775-4530 OR 801-775-4530 OR DSN 775-6548 OR 801-775-6548; BOX OF TWELVE (12),
SIXTEEN (16) OUNCE BOTTLES

SUPPLEMENTARY FEATURES:

NO OTHER PART NUMBERS SHOULD BE ADDED

National Stock Number

FSC	FSG	NIIN	INC
7930	79	01-581-9933 / 015819933	15614

5602260

Plastic Polish

CRITICALITY CODE
JUSTIFICATION:

SUPP

SPECIAL FEATURES:

PLASTIC POLISH TYPE II; IDENTIFIED BY USAF CONTROL NUMBER 200925154-03 FOR USE ON F-16 CANOPIES; WHIZ AIRCRAFT CLEANING COMPOUND - 5602260;
CONTACT HILL AFB FOR PRODUCT INQUIRY: 416 SCMS/GUMAE, DSN 775-4530 OR 801-775-4530 OR DSN 775-6548 OR 801-775-6548; BOX OF TWELVE (12),
SIXTEEN (16) OUNCE BOTTLES

SUPPLEMENTARY FEATURES:

NO OTHER PART NUMBERS SHOULD BE ADDED

National Stock Number

FSC	FSG	NIIN	INC
7930	79	01-581-9933 / 015819933	15614

4925-LG

Permeable Gloves

CLOTH NAME:	KNITTED OVERALL
COLOR:	GREEN, US ARMY, 109 OVERALL
CUFF TYPE:	KNIT WRIST
GARMENT SIZE:	LARGE
FIBER MATERIAL:	COTTON OVERALL
III USER DESIGNATOR:	MAN
PROCUREMENT GROUP CODE:	00523

Weight and Dimensions

Box Weight	Box Size	Item Weight	Item Dimensions
--	300 X 300 X 60	--	--

National Stock Number

FSC	FSG	NIIN	INC
8415	84	00-964-4925 / 009644925	32461

National Motor Freight / Schedule B

NMFC	Description	Schedule B
049920	GLOVES R MITTENS WORKMENS COTTON	9803100000 / Military wearing apparel of all types and materials, including footwear and headwear

RIT/PED/067

Personal Descender

GENERAL CHARACTERISTICS ITEM DESCRIPTION:

FIVE HOLES

MATERIAL:

ALUMINUM

OVERALL HEIGHT:

13.0 MILLIMETERS NOMINAL

OVERALL LENGTH:

73.0 MILLIMETERS NOMINAL

OVERALL WIDTH:

41.0 MILLIMETERS NOMINAL

PART NAME ASSIGNED BY CONTROLLING AGENCY:

PMI PED PERSONAL DESCENDER

SURFACE TREATMENT:

ANODIZE

National Stock Number

FSC	FSG	NIIN	INC
8465	84	01-524-7097 / 015247097	7777

8465-01-569-8803

Modern Army Combatives Kit

PART NAME ASSIGNED BY CONTROLLING AGENCY:

KIT,MODERN ARMY COMBATIVES (MACK)

Weight and Dimensions

National Stock Number

Box Weight	Box Size	Item Weight	Item Dimensions	FSC	FSG	NIIN	INC
--	--	--	--	8465	84	01-569-8803 / 015698803	7777

MC-101A

Crypto Ignition Key

END ITEM IDENTIFICATION: KG-175D

SPECIAL FEATURES: CRYPTO IGNITION KEY (CIK) FOR THE KG-175D MICRO ONLY SST SERIES SLIMLINE;HEIGHT:0.180 IN;WIDTH:0.730 IN;DEPTH:1.190 IN;WEIGHT:0.010 OZ;COLOR:GREY;MEMORY:16KB

Weight and Dimensions

National Stock Number

Box Weight	Box Size	Item Weight	Item Dimensions	FSC	FSG	NIIN	INC
1.5lbs	28 X 22 X 22	.0lbs	8 X 2 X 12	5810	58	01-559-1366 / 015591366	77777

5855-01-609-6819

Viewer Mount

NIGHT VISION EQUIPMENT, EMITTED AND REFLECTED RADIATION NATIONAL STOCK NUMBER 5855-01-609-6819 MOUNT,VIEWER.

Weight and Dimensions

National Stock Number

Box Weight	Box Size	Item Weight	Item Dimensions	FSC	FSG	NIIN	INC
--		--	--	5855	58	01-609-6819 / 016096819	38094

National Motor Freight / Schedule B

NMFC	Description	Schedule B
146450	MOUNTS FOR SIGHTING EQUIP	

OS37-3215-A1

Communication Equ Interface Unit

MISCELLANEOUS COMMUNICATION EQUIPMENT NATIONAL STOCK NUMBER 5895-01-623-2807 INTERFACE UNIT,COMMUNICATION EQU.

National Motor Freight / Schedule B

National Stock Number

NMFC	Description	Schedule B	FSC	FSG	NIIN	INC
061700	ELEC APPLIANCES/INSTRUMENTS		5895	58	01-623-2807 / 016232807	42127

RWR89S2R40DS

Wire Wound Fixed Resistor

ELECTRICAL RESISTANCE:	2.400 OHMS
AMBIENT TEMP IN DEG CELSIUS AT FULL RATED POWER:	25.0
AMBIENT TEMP IN DEG CELSIUS AT ZERO PERCENT RATED POWER:	275.0
BODY DIAMETER:	0.187 INCHES NOMINAL
BODY LENGTH:	0.560 INCHES NOMINAL
CUBIC MEASURE:	0.019 CUBIC INCHES
INCLOSURE METHOD:	ENCAPSULATED
REACTANCE CHARACTERISTIC:	INDUCTIVE
RELIABILITY FAILURE RATE LEVEL IN PERCENT:	0.001
RELIABILITY INDICATOR:	ESTABLISHED
RESISTANCE TOLERANCE IN PERCENT:	-0.500/+0.500
POWER DISSIPATION RATING IN WATTS:	3.000 FREE AIR
SPECIFICATION/STANDARD DATA:	81349-MIL-R-39007/11 GOVERNMENT SPECIFICATION
STYLE DESIGNATOR:	AXIAL TERMINAL EACH END
TEMP RANGE OF TEMP COEFFICIENT IN DEG CELSIUS:	-55.0/+275.0
TEMP COEFFICIENT OF RESISTANCE IN PPM PER DEG CELSIUS:	-50.0/+50.0
TERMINAL LENGTH:	1.500 INCHES MINIMUM

Weight and Dimensions

National Stock Number

Box Weight	Box Size	Item Weight	Item Dimensions	FSC	FSG	NIIN	INC
.1lbs	--	--	--	5905	59	01-191-1994 / 011911994	00010

National Motor Freight / Schedule B

NMFC	Description	Schedule B
062960	REOSTATS/PARTS	8533390080 / Wirewound variable resistors

1413-BNCC

Electrical Receptacle Connector

END ITEM IDENTIFICATION:

TYPE 1413 PRECISION DECADE CAPACITOR

National Stock Number

FSC	FSG	NIIN	INC
5935	59	01-538-4946 / 015384946	15093

PHP440

Diode Semiconductor Device

CURRENT RATING PER CHARACTERISTIC:	13.20 AMPERES SOURCE CUTOFF CURRENT UNIVERSAL
FUNCTION FOR WHICH DESIGNED:	TRANSIENT SUPPRESSOR
MAXIMUM OPERATING TEMP PER MEASUREMENT POINT:	175.0 DEG CELSIUS AMBIENT AIR
MOUNTING METHOD:	TERMINAL
OVERALL HEIGHT:	0.530 INCHES MAXIMUM
INCLOSURE MATERIAL:	PLASTIC
SEMICONDUCTOR MATERIAL:	SILICON
OVERALL LENGTH:	2.280 INCHES MAXIMUM
OVERALL WIDTH:	1.405 INCHES MAXIMUM
POWER RATING PER CHARACTERISTIC:	15.0 MILLIWATTS SMALL-SIGNAL INPUT POWER, COMMON-COLLECTOR MAJOR
VOLTAGE RATING IN VOLTS PER CHARACTERISTIC:	440.0 MAXIMUM NOMINAL REGULATOR VOLTAGE
TERMINAL LENGTH:	0.365 INCHES MAXIMUM
TERMINAL TYPE AND QUANTITY:	2 TURRET

Weight and Dimensions

National Stock Number

Box Weight	Box Size	Item Weight	Item Dimensions	FSC	FSG	NIIN	INC
.2lbs	--	--	--	5961	59	01-317-1940 / 013171940	20589

National Motor Freight / Schedule B

NMFC	Description	Schedule B
063025	SEMICONDUCTORS/DEVICES ETC	8541100070 / Diodes, other than photosensitive or led, with a maximum current of 0.5 a or less

223-14535-2

Battery Set

COMPONENT QUANTITY: 6
END ITEM IDENTIFICATION: UPS1-1.25K-1G-SRNDTI-J2E(1BCN7), UPS RIC MT DGTL;1.5K
PART NAME ASSIGNED BY CONTROLLING AGENCY: INAVY)BATTERY PACK, PWR SU
SUPPLY ITEMS AND QUANTITIES: 6140013657743, NP7-12, 6

Weight and Dimensions

National Stock Number

Box Weight	Box Size	Item Weight	Item Dimensions	FSC	FSG	NIIN	INC
18.0lbs	--	--	--	6140	61	01-530-6548 / 015306548	22445

National Motor Freight / Schedule B

NMFC	Description	Schedule B
060960	BATTERY SETS IN BATTERY BOXES	

89115957-1

Electrical Cable Protector

OVERALL LENGTH:

20.250 INCHES NOMINAL

STYLE DESIGNATOR:

DUCT SHIELD

Weight and Dimensions

National Stock Number

Box Weight	Box Size	Item Weight	Item Dimensions	FSC	FSG	NIIN	INC
10.3lbs	--	--	--	5975	59	01-441-7561 / 014417561	00111

National Motor Freight / Schedule B

NMFC	Description	Schedule B
160310	PROTECTORS CABLE GROUND/GUY WIRE	8543909000 / Electrical machines and apparatus parts

10250287-1

Tip Plug

ELECTRICAL INSULATION FEATURE:	INSULATED COMPLETELY
BODY LENGTH:	2.500 INCHES MINIMUM AND 2.630 INCHES MAXIMUM
BODY STYLE:	STRAIGHT HANDLE
CABLE ENTRANCE DIAMETER:	0.320 INCHES MINIMUM AND 0.350 INCHES MAXIMUM
FINGER DIAMETER:	0.375 INCHES NOMINAL SINGLE FINGER
FINGER LENGTH:	0.937 INCHES MINIMUM AND 1.063 INCHES MAXIMUM SINGLE FINGER
IDENTIFICATION CODE COLOR:	NATURAL
III END ITEM IDENTIFICATION:	1440-01-087-9844 LAUNCHING STATION,GUIDED MISSILE,SEMITRAILER MOUNTED
MATERIAL:	BERYLLIUM COPPER TERMINAL
MATERIAL:	BERYLLIUM COPPER FINGER
MATERIAL:	PLASTIC, PHENOLIC RESIN, PAPER BASE HANDLE
MATERIAL:	PLASTIC, PHENOLIC RESIN, PAPER BASE INSULATOR
OVERALL DIAMETER:	0.980 INCHES MINIMUM AND 1.020 INCHES MAXIMUM
III FINGER TYPE:	SPLIT END SINGLE FINGER
OVERALL LENGTH:	3.437 INCHES MINIMUM AND 3.693 INCHES MAXIMUM
SPECIAL FEATURES:	ITEM IS FURNISHED WITH A COVER
SURFACE TREATMENT:	NICKEL FINGER

Weight and Dimensions

Box Weight	Box Size	Item Weight	Item Dimensions
.3lbs	--	--	--

National Motor Freight / Schedule B

NMFC	Description	Schedule B
------	-------------	------------

061680

ELEC WIRING PLUGS
ETC

8548900100 / Electrical parts of machinery or
apparatus not specified or included elsewhere in
chapter 85

National Stock Number

FSC	FSG	NIIN	INC
5935	59	01-260-7742 / 012607742	15046

68000-100-1

Printed Circuit Board

III END ITEM IDENTIFICATION:

HYDRAULICS INTERNATIONAL INC. DHPS HYDRAULIC POWER SUPPLY, DIESEL.

Weight and Dimensions

National Stock Number

Box Weight	Box Size	Item Weight	Item Dimensions	FSC	FSG	NIIN	INC
--	85	--	--	5998	59	01-568-6978 / 015686978	60843

National Motor Freight / Schedule B

NMFC	Description	Schedule B
061045	BOARDS PRINTED CIRCUIT ELEC	

MHO + 13FAD11.034482

Crystal Controlled Oscillator

AVERAGE LIFE MEASUREMENT:	HOURS
AVERAGE LIFE RATING:	2000000.0
BASIC SHAPE STYLE:	RECTANGULAR OR SQUARE
CONNECTION CONTACT TYPE AND QUANTITY:	14 PIN EXTERNAL
CONNECTION TYPE AND LOCATION:	PIN BOTTOM
CONTROL TYPE:	REMOTE
ENVIRONMENTAL PROTECTION:	MOISTURE PROOF AND SHOCK RESISTANT AND VIBRATION
EXTERNAL DC OPERATING VOLTAGE IN VOLTS:	5.0 NOMINAL SINGLE VOLTAGE
FREQUENCY PER CHANNEL:	11.034482 MEGAHERTZ NOMINAL OPERATING CHANNEL
IDENTIFICATION DESIGNATOR:	K1091A-11.034482MHZ-04713
III CIRCUIT CONSTRUCTION TYPE:	SOLID STATE
OPERATING CONTROL METHOD:	AUTOMATIC
OPERATING TEMP RANGE:	-0.0 TO 70.0 DEG CELSIUS
OVERALL HEIGHT:	0.565 INCHES NOMINAL
OVERALL LENGTH:	0.750 INCHES NOMINAL
III FSC APPLICATION DATA:	CIRCUIT CARD ASSEMBLY,PART NO. 123254-1,RADAR SET,JETDS,TYPE NO. AN/TPS43D
INCLOSURE TYPE:	ENCASED

Weight and Dimensions

Box Weight	Box Size	Item Weight	Item Dimensions
.1lbs	--	--	--

National Motor Freight / Schedule B

NMFC	Description	Schedule B
------	-------------	------------

061700 ELEC APPLIANCES/INSTRUMENTS

8541600060 / Mounted piezoelectric
crystals, quartz, designed for operating
frequencies exceeding 20 mhz

National Stock Number

FSC	FSG	NIIN	INC
5955	59	01-010-2803 / 010102803	34690

MCH2711A3

Switch Actuator Adapter

END ITEM IDENTIFICATION: C-130 HERCULES, AC-130H, MC-130H, EC-130E, HC-130 AIRCRAFT.
ACTUATOR ADAPTER STYLE: PUSHBUTTON
FEATURES PROVIDED: ADJUSTABLE
MOUNTING METHOD: THREADED STUD

Weight and Dimensions

National Stock Number

Box Weight	Box Size	Item Weight	Item Dimensions	FSC	FSG	NIIN	INC
--	--	--	--	5930	59	00-990-5195 / 009905195	05315

National Motor Freight / Schedule B

NMFC	Description	Schedule B
061300	CIRCUIT BREAKER/SWITCH	8538907080 / Parts suitable for use solely or principally with the apparatus for heading 8535, 8536,8537

388031-1

Digital Microcircuit

MICROCIRCUITS, ELECTRONIC NATIONAL STOCK NUMBER 5962-01-350-3922 MICROCIRCUIT,DIGITAL.

Weight and Dimensions

National Stock Number

Box Weight	Box Size	Item Weight	Item Dimensions	FSC	FSG	NIIN	INC
.1lbs	--	--	--	5962	59	01-350-3922 / 013503922	31779

National Motor Freight / Schedule B

NMFC	Description	Schedule B
061700	ELEC APPLIANCES/INSTRUMENTS	8542900000 / Electronic integrated circuits and microassembly parts

M27-318-05

Power Transformer

BODY HEIGHT:	4.130 INCHES NOMINAL
BODY LENGTH:	3.130 INCHES NOMINAL
BODY WIDTH:	2.630 INCHES NOMINAL
CENTER TO CENTER DISTANCE BETWEEN MOUNTING FACILITIES PARALLEL TO LENGTH:	2.250 INCHES NOMINAL SINGLE MOUNTING FACILITY SINGLE CENTER GROUP
CENTER TO CENTER DISTANCE BETWEEN MOUNTING FACILITIES PARALLEL TO WIDTH:	2.000 INCHES NOMINAL SINGLE MOUNTING FACILITY SINGLE CENTER GROUP
FREQUENCY RATING:	60.0 HERTZ NOMINAL SINGLE COMPONENT
MAXIMUM TRANSFORMER POWER RATING:	80.0 VOLT-AMPERE SINGLE COMPONENT
MOUNTING FACILITY QUANTITY:	4 SINGLE GROUP
MOUNTING METHOD:	THREADED HOLE SINGLE GROUP
NOMINAL THREAD SIZE:	0.164 INCHES SINGLE GROUP
INCLOSURE TYPE:	FULLY INCLOSED
INPUT-OUTPUT PHASE RELATIONSHIP:	SINGLE PHASE TO SINGLE PHASE SINGLE COMPONENT
RELIABILITY INDICATOR:	NOT ESTABLISHED
SPECIFICATION/STANDARD DATA:	81349-MIL-T-27/318 GOVERNMENT SPECIFICATION
WINDING FUNCTION AND QUANTITY:	1 PRIMARY SINGLE COMPONENT AND 1 SECONDARY SINGLE COMPONENT
WINDING OPERATING CURRENT:	6.35 AMPERES DC MAXIMUM SINGLE COMPONENT SINGLE SECONDARY
WINDING OPERATING VOLTAGE:	115.00 AC VOLTS NOMINAL SINGLE COMPONENT SINGLE PRIMARY

National Stock Number

FSC	FSG	NIIN	INC
5950	59	01-315-1397 / 013151397	32496

5915-01-385-6099

Radio Frequency Interfere Filter

BODY HEIGHT:	3.030 INCHES MAXIMUM
BODY LENGTH:	4.540 INCHES MAXIMUM
BODY WIDTH:	1.170 INCHES MAXIMUM
FUNCTIONAL TERMINAL TYPE AND QUANTITY:	1 CONNECTOR, RECEPTACLE INPUT 1ST FUNCTION
FUNCTIONAL TERMINAL TYPE AND QUANTITY:	1 TAB, SOLDER LUG GROUND 3RD FUNCTION
FUNCTIONAL TERMINAL TYPE AND QUANTITY:	2 TAB, SOLDER LUG OUTPUT 2ND FUNCTION
MOUNTING FACILITY TYPE AND QUANTITY:	2 THREADED HOLE
MOUNTING FACILITY SCREW THREAD SERIES DESIGNATOR:	UNF
NOMINAL THREAD SIZE:	0.190 INCHES
OPERATING CURRENT RATING PER FUNCTION IN AMPS:	5.5 1ST RADIO INTERFERENCE
OPERATING CURRENT RATING PER FUNCTION IN AMPS:	5.5 2ND RADIO INTERFERENCE
OPERATING VOLTAGE RATING AND TYPE PER FUNCTION:	117.0 VOLTS AC 1ST RADIO INTERFERENCE 1ST FUNCTION
OPERATING VOLTAGE RATING AND TYPE PER FUNCTION:	117.0 VOLTS AC 2ND RADIO INTERFERENCE 2ND FUNCTION
OVERALL HEIGHT:	3.655 INCHES NOMINAL
INCLOSURE TYPE:	ENCASED
STYLE DESIGNATOR:	RECTANGULAR TERMINAL/TERMINALS ON OPPOSITE SURFACES

Weight and Dimensions

National Stock Number

Box Weight	Box Size	Item Weight	Item Dimensions	FSC	FSG	NIIN	INC
.1lbs	50 X 40 X 30	--	--	5915	59	01-385-6099 / 013856099	00765

National Motor Freight / Schedule B

NMFC	Description	Schedule B
061990	ELECTRICAL EQUIP:FILTERS	8527995030 / Reception apparatus

372-2601-021

Electrical Contact

CURRENT RATING IN AMPS:	3.0
MATERIAL DOCUMENT AND CLASSIFICATION:	QQ-B-750,ALLOY CDA 510,GRADE FED SPEC SINGLE MATERIAL RESPONSE BODY AND CONTACT
MATERIAL:	COPPER ALLOY 510 BODY AND CONTACT
MOUNTING METHOD:	FORCE FIT
OVERALL HEIGHT:	0.024 INCHES MINIMUM AND 0.026 INCHES MAXIMUM
OVERALL LENGTH:	0.790 INCHES MINIMUM AND 0.810 INCHES MAXIMUM
III STYLE DESIGNATOR:	POST CONTACT
OVERALL WIDTH:	0.040 INCHES MINIMUM AND 0.042 INCHES MAXIMUM
PIN LENGTH:	0.575 INCHES MINIMUM AND 0.595 INCHES MAXIMUM
PIN WIDTH:	0.024 INCHES MINIMUM AND 0.026 INCHES MAXIMUM
PRECIOUS MATERIAL AND LOCATION:	BODY AND CONTACT SURFACES GOLD
PRECIOUS MATERIAL AND WEIGHT:	0.005 GOLD GRAINS, TROY
PRECIOUS MATERIAL:	GOLD
SURFACE TREATMENT DOCUMENT AND CLASSIFICATION:	MIL-G-45204,TYPE 2 MIL SPEC 1ST TREATMENT RESPONSE AND QQ-N-290,CLASS 2 FED SPEC 2ND TREATMENT RESPONSE BODY AND CONTACT
SURFACE TREATMENT:	GOLD AND NICKEL AND COPPER BODY AND CONTACT
TERMINAL TYPE AND QUANTITY:	1 WIRE WRAP END OPPOSITE CONTACT

Weight and Dimensions

National Stock Number

Box Weight	Box Size	Item Weight	Item Dimensions	FSC	FSG	NIIN	INC
.1lbs	--	--	--	5999	59	01-229-7338 / 012297338	00443

National Motor Freight / Schedule B

NMFC	Description	Schedule B
061300	CIRCUIT BREAKER/SWITCH	8538907040 / Electrical metal contacts for heading 8535, 8536 & 8537

1564XBLKCA020KT

Electric Insulating Compound Kit

DOCUMENT IDENTIFICATION: PR-1564
DOCUMENT SOURCE: 83574
DOCUMENT TYPE: INDUSTRIAL SPECIFICATION
COMPONENT DOCUMENT ORIGIN: INDUSTRIAL
COMPONENT DOCUMENT PAGE NUMBER: 2
COMPONENT QUANTITY: 2
III CONTAINER TYPE: CAN
SPECIAL FEATURES: PRIMER REQUIRED ON METAL SURFACES

Weight and Dimensions

National Stock Number

Box Weight	Box Size	Item Weight	Item Dimensions	FSC	FSG	NIIN	INC
--		--	--	5970	59	00-489-0511 / 004890511	32318

National Motor Freight / Schedule B

NMFC	Description	Schedule B
103660	ELECTRIC WIRE OR WIRING	

5975-01-309-1794

Dust And Moisture Seal Boot

BASE OVERALL LENGTH: 3.500 INCHES NOMINAL
BASE WIDTH: 4.370 INCHES NOMINAL
CENTER TO CENTER DISTANCE BETWEEN MOUNTING FACILITIES PARALLEL TO WIDTH: 1.500 INCHES NOMINAL
MATERIAL: RUBBER SILICONE BODY

Weight and Dimensions

National Stock Number

Box Weight	Box Size	Item Weight	Item Dimensions	FSC	FSG	NIIN	INC
.3lbs	--	--	--	5975	59	01-309-1794 / 013091794	19302

National Motor Freight / Schedule B

NMFC	Description	Schedule B
060500	ELECTRICAL EQUIPMENT GROUP	8543909000 / Electrical machines and apparatus parts

4391S14-158

Thermostatic Switch

SWITCHES NATIONAL STOCK NUMBER 5930-01-436-1807 SWITCH,THERMOSTATIC.

Weight and Dimensions

National Stock Number

Box Weight	Box Size	Item Weight	Item Dimensions	FSC	FSG	NIIN	INC
--	--	--	--	5930	59	01-436-1807 / 014361807	00451

National Motor Freight / Schedule B

NMFC	Description	Schedule B
061300	CIRCUIT BREAKER/SWITCH	9032100000 / Thermostats

C84532-002

Electrical Receptacle Connector

END ITEM IDENTIFICATION:

COMMUNICATIONS SYSTEM,AN/TRN-26

SPECIAL FEATURES:

CONNECTOR,RF,SMA

National Stock Number

FSC	FSG	NIIN	INC
5935	59	01-553-3731 / 015533731	15093

77C716202P001

Electrolytic Fixed Capacitor

ELECTRICAL POLARIZATION:	POLARIZED
ANODE TYPE:	PLAIN FOIL
BODY DIAMETER:	2.000 INCHES NOMINAL
BODY LENGTH:	5.625 INCHES NOMINAL
BODY STYLE:	W/O MTG FACILITIES, TERMINAL(S) ON ONE END
CAPACITIVE ELECTRODE MATERIAL:	ALUMINUM
CAPACITANCE VALUE PER SECTION:	4700.000 MICROFARADS SINGLE SECTION
CASE INSULATION MATERIAL:	PLASTIC
CASE MATERIAL:	METAL
CENTER TO CENTER DISTANCE BETWEEN TERMINALS PARALLEL TO DIAMETER:	0.875 INCHES NOMINAL
DC LEAKAGE AT MAXIMUM OPERATING TEMP:	4.1 MILLIAMPERES
DC LEAKAGE AT REFERENCE TEMP:	0.680 MILLIAMPERES
EQUIVALENT SERIES RESISTANCE AT REFERENCE TEMP IN OHMS:	0.013
MOUNTING FACILITY TYPE AND QUANTITY:	2 THREADED MOUNTING HOLES
MOUNTING FACILITY SCREW THREAD SERIES DESIGNATOR:	UNF
NOMINAL THREAD SIZE:	0.190 INCHES
NONDERATED OPERATING TEMP:	-55.0 DEG CELSIUS MINIMUM AND 85.0 DEG CELSIUS MAXIMUM

Weight and Dimensions

Box Weight	Box Size	Item Weight	Item Dimensions
.5lbs	80 X 80 X 40	--	--

National Motor Freight / Schedule B

National Stock Number

NMFC	Description	Schedule B	FSC	FSG	NIIN	INC
061400	CONDENSERS/PARTS/CAPACITORS	8532290040 / Fixed capacitors	5910	59	01-113-2890 / 011132890	00008

M49450/5-BB-716/A

Branched Wiring Harness

END ITEM IDENTIFICATION:

HELICOPTER, SEARCH AND RESCUE; HELICOPTER CARRIER BASED; LAMPS MARK III,SH-60B HELICOPTER

PART NAME ASSIGNED BY CONTROLLING AGENCY:

HARNES ASSEMBLY

Weight and Dimensions

National Stock Number

Box Weight	Box Size	Item Weight	Item Dimensions	FSC	FSG	NIIN	INC
.2lbs	--	--	--	6150	61	01-162-5234 / 011625234	61341

National Motor Freight / Schedule B

NMFC	Description	Schedule B
061130	CABLE ASSEMBLY	8543909000 / Electrical machines and apparatus parts

9454297-3

Circuit Card Assembly

END ITEM IDENTIFICATION:

4120014490459

III PART NAME ASSIGNED BY CONTROLLING AGENCY:

PRINTED WIRING ASSEMBLY, HEAT PUMP CONTROL

Weight and Dimensions

National Stock Number

Box Weight	Box Size	Item Weight	Item Dimensions	FSC	FSG	NIIN	INC
1.7lbs	--	--	--	5998	59	01-493-8522 / 014938522	61638

National Motor Freight / Schedule B

NMFC	Description	Schedule B
061045	BOARDS PRINTED CIRCUIT ELEC	8542900000 / Electronic integrated circuits and microassembly parts

5465221-001

E Special Purpose Cable Assembly

MISCELLANEOUS ELECTRIC POWER AND DISTRIBUTION EQUIPMENT NATIONAL STOCK NUMBER 6150-01-615-6590 CABLE ASSEMBLY,SPECIAL PURPOSE,E.

Weight and Dimensions

National Stock Number

Box Weight	Box Size	Item Weight	Item Dimensions	FSC	FSG	NIIN	INC
--		--	--	6150	61	01-615-6590 / 016156590	00782

National Motor Freight / Schedule B

NMFC	Description	Schedule B
061130	CABLE ASSEMBLY	

10483A

Dynamic Microphone

HEIGHT: 2.000 INCHES NOMINAL
LENGTH: 10.000 INCHES NOMINAL
WIDTH: 1.000 INCHES NOMINAL
UNPACKAGED UNIT WEIGHT: 10.0 POUNDS

Weight and Dimensions

National Stock Number

Box Weight	Box Size	Item Weight	Item Dimensions	FSC	FSG	NIIN	INC
10.6lbs	130 X 40 X 30	--	--	5965	59	01-440-8257 / 014408257	00362

T295111

E Special Purpose Cable Assembly

SPECIAL FEATURES: 1 PLUG CAP, 1 FEMALE CONECTOR, 1 CAGE CLAMP ASSY, 1 14/3 SEOW SJ CORD, 5FT. 1 MALE 120V, PLUG
STYLE DESIGNATOR: INTERNAL AND EXTERNAL CONNECTOR
USAGE DESIGN: POWER

Weight and Dimensions

National Stock Number

Box Weight	Box Size	Item Weight	Item Dimensions	FSC	FSG	NIIN	INC
--		--	--	5995	59	01-552-8232 / 015528232	00782

National Motor Freight / Schedule B

NMFC	Description	Schedule B
061130	CABLE ASSEMBLY	

2137809G001

Grounding Terminal Strip

MATERIAL:	PHOSPHOR BRONZE, SPRING TEMPER
MOUNTING METHOD:	FRICTION
OVERALL LENGTH:	4.000 INCHES NOMINAL
OVERALL THICKNESS:	0.010 INCHES NOMINAL
OVERALL WIDTH:	0.500 INCHES NOMINAL
WIRE ACCOMMODATION QUANTITY:	2
WIRE ACCOMMODATION SIZE:	ONE HOLE 0.196 IN. DIA; ONE HOLE 0.265 IN. DIA
SURFACE TREATMENT:	CADMIUM, QQ-P-416, TYPE 1, CLASS B
UNIT TYPE:	PLATE

Weight and Dimensions

National Stock Number

Box Weight	Box Size	Item Weight	Item Dimensions	FSC	FSG	NIIN	INC
.1lbs		--	--	5940	59	00-571-4673 / 005714673	15244

National Motor Freight / Schedule B

NMFC	Description	Schedule B
106120	PLATE/SHEET/STRIP I/S	8548900100 / Electrical parts of machinery or apparatus not specified or included elsewhere in chapter 85

1600-1273

Solid State Flasher

END ITEM IDENTIFICATION: FA10048
MOUNTING CONFIGURATION: 1 SCREW WITH TAP
OVERALL HEIGHT: 1.500 INCHES NOMINAL
OVERALL LENGTH: 2.875 INCHES NOMINAL
OVERALL WIDTH: 2.000 INCHES NOMINAL
TERMINAL QUANTITY: 8
TERMINAL TYPE: WIRE LEAD AND WIRE LEAD W/SOLDER LUG

National Stock Number

FSC	FSG	NIIN	INC
5945	59	01-294-4633 / 012944633	36776

5465221-001

E Special Purpose Cable Assembly

MISCELLANEOUS ELECTRIC POWER AND DISTRIBUTION EQUIPMENT NATIONAL STOCK NUMBER 6150-01-615-6590 CABLE ASSEMBLY,SPECIAL PURPOSE,E.

Weight and Dimensions

National Stock Number

Box Weight	Box Size	Item Weight	Item Dimensions	FSC	FSG	NIIN	INC
--		--	--	6150	61	01-615-6590 / 016156590	00782

National Motor Freight / Schedule B

NMFC	Description	Schedule B
061130	CABLE ASSEMBLY	

VA260-5.50T2

Electrical Card Holder

END ITEM IDENTIFICATION: C-17A AIRCRAFT
III BODY STYLE: SCREW WEDGE
MATERIAL DOCUMENT AND CLASSIFICATION: SAE-AMS-QQ-A-200/8, TYPE 6061-T6 ASSN STD 1ST MATERIAL RESPONSE AND ASTM A582, TYPE 303, 303SE, OR 303SU ASSN STD 2ND MATERIAL RESPONSE
MATERIAL: ALUMINUM ALLOY 6061 AND STEEL CORROSION RESISTING
MOUNTING FACILITY TYPE AND QUANTITY: 2 THREADED HOLE SINGLE MOUNTING FACILITY
NOMINAL THREAD SIZE: 0.086 INCHES SINGLE MOUNTING FACILITY
OVERALL HEIGHT: 0.260 INCHES NOMINAL
OVERALL LENGTH: 5.500 INCHES NOMINAL
OVERALL WIDTH: 0.250 INCHES NOMINAL
PART NAME ASSIGNED BY CONTROLLING AGENCY: HOLDER, ELECTRICAL CARD, WEDGE RETAINER, 5-PIECE, .250 INCH BY .260 INCH BODY SIZE
SURFACE TREATMENT DOCUMENT AND CLASSIFICATION: MIL-A-8625, TYPE I OR II, CLASS 2 MIL STD SINGLE TREATMENT RESPONSE
SURFACE TREATMENT: ANODIZE
THREAD SERIES DESIGNATOR: UNF SINGLE MOUNTING FACILITY

National Stock Number

FSC	FSG	NIIN	INC
5998	59	01-549-7572 / 015497572	31930

5465221-001

E Special Purpose Cable Assembly

MISCELLANEOUS ELECTRIC POWER AND DISTRIBUTION EQUIPMENT NATIONAL STOCK NUMBER 6150-01-615-6590 CABLE ASSEMBLY,SPECIAL PURPOSE,E.

Weight and Dimensions

National Stock Number

Box Weight	Box Size	Item Weight	Item Dimensions	FSC	FSG	NIIN	INC
--		--	--	6150	61	01-615-6590 / 016156590	00782

National Motor Freight / Schedule B

NMFC	Description	Schedule B
061130	CABLE ASSEMBLY	

W-2438-2282

Electrical Power Cable

END ITEM IDENTIFICATION:	ENGINE INTERFACE
ACCESSORY WIRE TYPE AND QUANTITY:	1 DRAIN
COLOR:	WHITE CORE PRIMARY INSULATION FIRST CONDUCTOR
COLOR:	WHITE CORE CONDUCTOR SECOND CONDUCTOR
COLOR:	WHITE CORE CONDUCTOR THIRD CONDUCTOR
CONDUCTOR FORM:	STRANDED ALL CONDUCTORS
CROSS-SECTIONAL SHAPE STYLE:	ROUND
III CONDUCTOR QUANTITY:	3
III MATERIAL:	COPPER ALLOY 1ST POSITION SHIELD FOIL CABLE
III MATERIAL:	COPPER CORE CONDUCTOR ALL CONDUCTORS
III MATERIAL:	PLASTIC CROSS-LINKED ETHYLENE TETRAFLUOROETHYLENE 2ND POSITION JACKET CABLE
III MATERIAL:	PLASTIC CROSS-LINKED ETHYLENE TETRAFLUOROETHYLENE CORE PRIMARY INSULATION ALL CONDUCTORS
ROUND CONDUCTOR SIZE:	16 AWG ALL CONDUCTORS
PART NAME ASSIGNED BY CONTROLLING AGENCY:	CABLE, 3 CONDUCTOR, SHIELDED
VOLTAGE RATING:	600.0 MAXIMUM ROOT MEAN SQUARE (RMS) OPERATING VOLTAGE ALL CONDUCTORS
STRAND AWG SIZE PER CONDUCTOR:	29 ALL CONDUCTORS
STRAND QUANTITY PER CONDUCTOR:	19 ALL CONDUCTORS

Weight and Dimensions

Box Weight	Box Size	Item Weight	Item Dimensions
.1lbs	--	--	--

National Motor Freight / Schedule B

National Stock Number

NMFC	Description	Schedule B	FSC	FSG	NIIN	INC
030310	CABLE OR WIRE	8544606000 / Insulated electric conductors for a voltage exceeding 1000 v	6145	61	01-530-1295 / 015301295	00232

N100735-00

Terminal Box

END ITEM IDENTIFICATION:

NAVY CODES 72A090001 THRU 72A090007

PART NAME ASSIGNED BY CONTROLLING AGENCY:

CREW CONNECTION POINT CCP-V5

Weight and Dimensions

National Stock Number

Box Weight	Box Size	Item Weight	Item Dimensions	FSC	FSG	NIIN	INC
--	--	--	--	5940	59	01-583-6764 / 015836764	00452

National Motor Freight / Schedule B

NMFC	Description	Schedule B
063160	SWITCH BOXES/ELEC ENCLOSURES	

N100734-01

Radio Frequency Cable Assembly

END ITEM IDENTIFICATION:

BOAT, HARBOR SECURITY, 27FT, 27HS0801 THRU 27HS0807

OVERALL LENGTH:

20.000 FEET

PART NAME ASSIGNED BY CONTROLLING AGENCY:

CREW CONNECTION CABLE

SPECIAL FEATURES:

LVIS; CCC-V5.20

Weight and Dimensions

National Stock Number

Box Weight	Box Size	Item Weight	Item Dimensions	FSC	FSG	NIIN	INC
--		--	--	5995	59	01-582-4061 / 015824061	00886

National Motor Freight / Schedule B

NMFC	Description	Schedule B
061130	CABLE ASSEMBLY	

7121104 20T8410

Circuit Breaker

CIRCUIT BREAKERS NATIONAL STOCK NUMBER 5925-14-361-3824 BREAKER, CIRCUIT.

National Stock Number

FSC	FSG	NIIN	INC
		-- /	

DTS-3102

Thermostatic Switch

END ITEM IDENTIFICATION:

IISC PARTS INTRR COMMUNICATIONS LCS 0001.

OPERATING TEMP RATING:

20.0 DEG CELSIUS MINIMUM AND 60.0 DEG CELSIUS MAXIMUM

PART NAME ASSIGNED BY CONTROLLING AGENCY:

THERMOSTAT

National Motor Freight / Schedule B

National Stock Number

NMFC	Description	Schedule B	FSC	FSG	NIIN	INC
061300	CIRCUIT BREAKER/SWITCH		5930	59	01-572-2701 / 015722701	00451

RV2LAYS A251A

Variable Nonwire Wound Resistor

ELECTRICAL RESISTANCE PER SECTION:	250.0 OHMS SINGLE SECTION
ACTUATOR TYPE:	SINGLE SHAFT
ACTUATOR TRAVEL CONTROL FEATURE:	STOPS
AMBIENT TEMP IN DEG CELSIUS PER SECTION AT FULL RATED POWER:	70.0 SINGLE SECTION
AMBIENT TEMP IN DEG CELSIUS PER SECTION AT ZERO PERCENT RATED POWER:	120.0 SINGLE SECTION
BODY DIAMETER:	0.890 INCHES MINIMUM AND 0.922 INCHES MAXIMUM
BODY LENGTH:	0.437 INCHES MINIMUM AND 0.469 INCHES MAXIMUM
BODY STYLE:	CYLINDRICAL BUSHING MOUNTED
MAXIMUM STARTING TORQUE:	6.00 INCH-OUNCES
MAXIMUM STOP TORQUE:	128.00 INCH-OUNCES
MOUNTING BUSHING LENGTH:	0.484 INCHES MINIMUM AND 0.516 INCHES MAXIMUM
MOUNTING METHOD:	LOCKING BUSHING
NONTURN DEVICE LOCATION:	AT 9 OCLOCK
NONTURN DEVICE RADIUS:	0.422 INCHES MINIMUM AND 0.454 INCHES MAXIMUM
OVERALL DIAMETER:	1.274 INCHES MAXIMUM
OVERALL LENGTH:	1.031 INCHES MINIMUM AND 1.125 INCHES MAXIMUM
RELIABILITY INDICATOR:	NOT ESTABLISHED

Weight and Dimensions

Box Weight	Box Size	Item Weight	Item Dimensions
--	--	--	--

National Motor Freight / Schedule B

National Stock Number

NMFC	Description	Schedule B	FSC	FSG	NIIN	INC
062960	REOSTATS/PARTS	8533400080 / Variable resistors, including potentiometers	5905	59	00-577-9816 / 005779816	37405

G8744-2020-5M

No Item Name Available

CONNECTORS, ELECTRICAL NATIONAL STOCK NUMBER 5935-01-220-7317 NO ITEM NAME AVAILABLE.

Weight and Dimensions

National Stock Number

Box Weight	Box Size	Item Weight	Item Dimensions	FSC	FSG	NIIN	INC
.3lbs	--	--	--	5935	59	01-220-7317 / 012207317	00000

DPX2MA26P-45P-34B-0201

CONNECTORS, ELECTRICAL NATIONAL STOCK NUMBER 5935-14-385-5434 .

National Stock Number

FSC	FSG	NIIN	INC
		-- /	

6140-01-585-4636

Battery Set

END ITEM IDENTIFICATION:

KGV-136B

SPECIAL FEATURES:

BATTERY PACK 3.9V

Weight and Dimensions

National Stock Number

Box Weight	Box Size	Item Weight	Item Dimensions	FSC	FSG	NIIN	INC
--		--	--	6140	61	01-585-4636 / 015854636	22445

National Motor Freight / Schedule B

NMFC	Description	Schedule B
060960	BATTERY SETS IN BATTERY BOXES	

8113-10-6P-SP-A3

Electrical Receptacle Connector

DISTANCE FROM MOUNTING SHOULDER TO FRONT FACE:	0.432 INCHES NOMINAL
BODY STYLE:	STRAIGHT SHAPE, EXTERNAL COUPLING
CENTER TO CENTER DISTANCE BETWEEN MOUNTING FACILITIES PARALLEL TO HEIGHT:	0.719 INCHES NOMINAL
CONNECTOR LOCKING METHOD:	BAYONET PIN
CONTACT MAXIMUM CURRENT RATING IN AMPS:	13.0 SINGLE MATING END SINGLE CONTACT GROUPING
CONTACT MATERIAL:	NICKEL ALLOY SINGLE MATING END SINGLE CONTACT GROUPING
CONTACT POSITION ARRANGEMENT STYLE:	10-6 SINGLE MATING END
CONTACT REMOVABILITY:	NONREMOVABLE SINGLE MATING END SINGLE CONTACT GROUPING
CONTACT SURFACE TREATMENT:	TIN SINGLE MATING END SINGLE CONTACT GROUPING
DISTANCE BETWEEN CENTERLINES OF MOUNTING FACILITIES PARALLEL TO BODY WIDTH:	0.719 INCHES NOMINAL
ENVIRONMENTAL PROTECTION:	HERMETIC
MATING END QUANTITY:	1
OVERALL HEIGHT:	0.938 INCHES NOMINAL
OVERALL LENGTH:	0.885 INCHES NOMINAL
INCLUDED CONTACT QUANTITY:	6 SINGLE MATING END SINGLE CONTACT GROUPING
INCLUDED CONTACT TYPE:	ROUND PIN SINGLE MATING END SINGLE CONTACT GROUPING
INSERT MATERIAL:	GLASS SINGLE MATING END

Weight and Dimensions

Box Weight	Box Size	Item Weight	Item Dimensions
.1lbs	--	--	--

National Motor Freight / Schedule B

NMFC	Description	Schedule B
------	-------------	------------

061680

ELEC WIRING PLUGS
ETC

8538907080 / Parts suitable for use solely or
principally with the apparatus for heading 8535,
8536,8537

National Stock Number

FSC	FSG	NIIN	INC
5935	59	00-727-3906 / 007273906	15093

3 B 2 4 - T C

Nonrechargeable Battery

BATTERY ELECTROLYTE:	LITHIUM
CRITICALITY CODE JUSTIFICATION:	ZZZY
OVERALL DIAMETER:	0.522 INCHES MINIMUM AND 0.544 INCHES MAXIMUM
REFERENCE NUMBER DIFFERENTIATING CHARACTERISTICS:	MATERIAL WILL BE IN ACCORDANCE WITH NAVICP M ACTIVITY HX QUALITY CONTROL,MANUFACTURING AND TESTING SPECIFICATIONS.
SHAPE:	CYLINDRICAL
OVERALL LENGTH:	1.969 INCHES MINIMUM AND 2.002 INCHES MAXIMUM
TERMINAL LOCATION:	BOTTOM AND TOP
TERMINAL QUANTITY:	2
VOLTAGE IN VOLTS:	3.95

Weight and Dimensions

National Stock Number

Box Weight	Box Size	Item Weight	Item Dimensions	FSC	FSG	NIIN	INC
--	--	--	--	6135	61	01-425-9687 / 014259687	35499

DK-621-1633-1P

Electrical Plug Connector

BODY STYLE:	STRAIGHT SHAPE, INTERNAL COUPLING
CABLE ENTRANCE DIAMETER:	0.165 INCHES MINIMUM AND 0.195 INCHES MAXIMUM
CONNECTOR CABLE STRAIN RELIEF METHOD:	CRIMP TYPE
CONNECTOR LOCKING METHOD:	BAYONET LATCH
CONTACT MATERIAL DOCUMENT AND CLASSIFICATION:	QQ-B-626,COMP 22 FED SPEC SINGLE MATERIAL RESPONSE SINGLE MATING END SINGLE CONTACT GROUPING
CONTACT MAXIMUM CURRENT RATING IN AMPS:	3.0 SINGLE MATING END SINGLE CONTACT GROUPING
CONTACT MAXIMUM FREQUENCY RATING:	2.0 MEGAHERTZ SINGLE MATING END SINGLE CONTACT GROUPING
CONTACT MATERIAL:	COPPER ALLOY SINGLE MATING END SINGLE CONTACT GROUPING
CONTACT POSITION ARRANGEMENT STYLE:	NONSTD SINGLE MATING END
CONTACT REMOVABILITY:	NONREMOVABLE SINGLE MATING END SINGLE CONTACT GROUPING
CONTACT SURFACE TREATMENT DOCUMENT AND CLASSIFICATION:	MIL-G-45204,TY 2,CL 1 MIL SPEC 1ST TREATMENT RESPONSE SINGLE MATING END SINGLE CONTACT GROUPING AND QQ-N-290,CL 1 FED SPEC 2ND TREATMENT RESPONSE SINGLE MATING END SINGLE CONTACT GROUPING
CONTACT SURFACE TREATMENT:	GOLD SINGLE MATING END SINGLE CONTACT GROUPING AND NICKEL SINGLE MATING END SINGLE CONTACT GROUPING
ENVIRONMENTAL PROTECTION:	CORROSION RESISTANT AND THERMAL SHOCK RESISTANT AND MOISTURE RESISTANT AND VIBRATION RESISTANT
MATING END QUANTITY:	1
OVERALL DIAMETER:	0.510 INCHES MAXIMUM
OVERALL LENGTH:	1.245 INCHES MINIMUM AND 1.275 INCHES MAXIMUM
INCLUDED CONTACT TYPE:	TRIAxIAL PIN SINGLE MATING END SINGLE CONTACT GROUPING

Weight and Dimensions

Box Weight	Box Size	Item Weight	Item Dimensions
.1lbs	13 X 5 X 5	--	--

National Motor Freight / Schedule B

NMFC	Description	Schedule B
------	-------------	------------

National Stock Number

FSC	FSG	NIIN	INC
5935	59	01-281-5534 / 012815534	01938

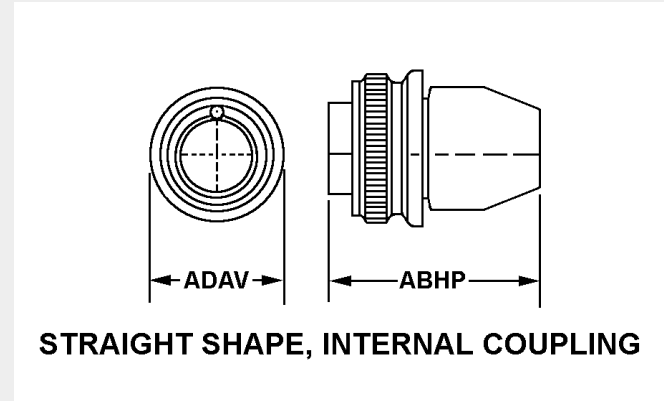

8MR3005CA

Direct Current Generator

SPECIAL FEATURES:

ALUMINUM CASE; STEEL STATOR; STEEL FAN; 24 VOLTS; 35 AMPS

Weight and Dimensions

National Stock Number

Box Weight	Box Size	Item Weight	Item Dimensions	FSC	FSG	NIIN	INC
8.7lbs	--	--	--	6115	61	01-459-1661 / 014591661	00512

National Motor Freight / Schedule B

NMFC	Description	Schedule B
062120	GENERATORS/MOTORS/PARTS	

539-230-004-698

Earphone Retainer F

HEADSETS, HANDSETS, MICROPHONES AND SPEAKERS NATIONAL STOCK NUMBER 5965-01-411-1181 EARPHONE RETAINER F.

National Stock Number

FSC	FSG	NIIN	INC
5965	59	01-411-1181 / 014111181	77777

5920-01-497-8779

Rectifier Fuse

END ITEM IDENTIFICATION:

POWER SUPPLY

Weight and Dimensions

National Stock Number

Box Weight	Box Size	Item Weight	Item Dimensions	FSC	FSG	NIIN	INC
--	--	--	--	5920	59	01-497-8779 / 014978779	7777

HM352-2E

Electrical Insulation Tape

ADHESIVE LOCATION:	ONE SIDE
ADHESIVE TYPE:	PRESSURE SENSITIVE
CUT TYPE AND QUANTITY:	1 SINGLE
DIELECTRIC WITHSTANDING VOLTAGE IN VOLTS:	7000.0
ENVIRONMENTAL PROTECTION:	HEAT RESISTANT AND SOLVENT RESISTANT
MATERIAL:	PLASTIC POLYETHYLENE OVERALL
NOMINAL LENGTH:	36.0 INCHES
NOMINAL OVERALL THICKNESS:	0.0035 INCHES
NOMINAL WIDTH:	0.002 INCHES
NONDEFINITIVE SPEC/STD DATA:	2 CLASS AND 2 TYPE
MATERIAL DOCUMENT AND CLASSIFICATION:	MIL-I-23594,TYPE 2,CLASS 2 MIL SPEC SINGLE MATERIAL RESPONSE OVERALL
TEMP RATING:	-75.0 DEG CELSIUS MINIMUM AND 260.0 DEG CELSIUS MAXIMUM

Weight and Dimensions

National Stock Number

Box Weight	Box Size	Item Weight	Item Dimensions	FSC	FSG	NIIN	INC
2.0lbs		--	--	5970	59	01-360-1809 / 013601809	33476

National Motor Freight / Schedule B

NMFC	Description	Schedule B
060500	ELECTRICAL EQUIPMENT GROUP	8546900000 / Electrical insulators

10-320-0135

E Special Purpose Cable Assembly

MISCELLANEOUS ELECTRIC POWER AND DISTRIBUTION EQUIPMENT NATIONAL STOCK NUMBER 6150-01-466-8698 CABLE ASSEMBLY,SPECIAL PURPOSE,E.

Weight and Dimensions

National Stock Number

Box Weight	Box Size	Item Weight	Item Dimensions	FSC	FSG	NIIN	INC
--	--	--	--	6150	61	01-466-8698 / 014668698	00782

National Motor Freight / Schedule B

NMFC	Description	Schedule B
061130	CABLE ASSEMBLY	8543909000 / Electrical machines and apparatus parts

5945-00-020-5213

Electromagnetic Relay

RELAYS AND SOLENOIDS NATIONAL STOCK NUMBER 5945-00-020-5213 RELAY,ELECTROMAGNETIC.

Weight and Dimensions

National Stock Number

Box Weight	Box Size	Item Weight	Item Dimensions	FSC	FSG	NIIN	INC
1.2lbs	30 X 30 X 25	--	--	5945	59	00-020-5213 / 000205213	32512

National Motor Freight / Schedule B

NMFC	Description	Schedule B
061300	CIRCUIT BREAKER/SWITCH	8536410050 / Relays, electromechanical, for a voltage not exceeding 60 v

5000-20302A2396

Electrical Plug Connector

III END ITEM IDENTIFICATION:

737 AEW&C

III PART NAME ASSIGNED BY CONTROLLING AGENCY:

CONNECTOR,PLUG,ELECTRICAL

National Stock Number

FSC	FSG	NIIN	INC
5935	59	01-624-7404 / 016247404	01938

5000-20301A2396

Electrical Plug Connector

III PART NAME ASSIGNED BY CONTROLLING AGENCY:

CONNECTOR ASSY-HALF

National Stock Number

FSC	FSG	NIIN	INC
5935	59	01-624-7427 / 016247427	01938

6145-00-110-4048

Electrical Special Purpose Cable

COLOR:	BLACK 1ST POSITION JACKET CABLE
CONDUCTOR ARRANGEMENT AND QUANTITY:	6 TWISTED PAIR
CONDUCTOR FORM:	SOLID ALL CONDUCTORS
CROSS SECTION OUTSIDE DIAMETER:	0.388 INCHES NOMINAL
CROSS-SECTIONAL SHAPE STYLE:	ROUND
III CONDUCTOR QUANTITY:	12
MATERIAL:	COPPER ALLOY 101 CORE CONDUCTOR ALL CONDUCTORS OR COPPER ALLOY 102 CORE CONDUCTOR ALL CONDUCTORS
MATERIAL:	PLASTIC POLYAMIDE 2ND POSITION JACKET ALL CONDUCTORS
MATERIAL:	PLASTIC POLYVINYL CHLORIDE 1ST POSITION PRIMARY INSULATION ALL CONDUCTORS
MATERIAL DOCUMENT AND CLASSIFICATION:	ASTM B33 ASSN STD ALL MATERIAL RESPONSES CORE CONDUCTOR ALL CONDUCTORS
ROUND CONDUCTOR SIZE:	24 AWG ALL CONDUCTORS
VOLTAGE RATING:	600.0 MAXIMUM ROOT MEAN SQUARE (RMS) OPERATING VOLTAGE ALL CONDUCTORS
SURFACE TREATMENT DOCUMENT AND CLASSIFICATION:	ASTM B33-63 ASSN STD SINGLE TREATMENT RESPONSE CORE CONDUCTOR ALL CONDUCTORS
SURFACE TREATMENT:	TIN CORE CONDUCTOR ALL CONDUCTORS

Weight and Dimensions

National Stock Number

Box Weight	Box Size	Item Weight	Item Dimensions	FSC	FSG	NIIN	INC
.1lbs	--	--	--	6145	61	00-110-4048 / 001104048	16488

National Motor Freight / Schedule B

NMFC	Description	Schedule B
030310	CABLE OR WIRE	8548900100 / Electrical parts of machinery or apparatus not specified or included elsewhere in chapter 85

PS-94-444-16

Electronic Frequency Converter

END ITEM IDENTIFICATION: CONVERTER ELEC FREQ; DBLWIDEMF MOBILE MAINT FACILITY, DOUBLEWIDE; MF TURNKEYA MOBILE MAINT FACILITY, TURNKEYA

BASIC SHAPE STYLE: RECTANGULAR OR SQUARE

OVERALL HEIGHT: 6.000 INCHES NOMINAL

OVERALL LENGTH: 18.000 INCHES NOMINAL

OVERALL WIDTH: 9.000 INCHES NOMINAL

PART NAME ASSIGNED BY CONTROLLING AGENCY: FREQUENCY MODULE; PS SERIES PROGRAMMABLE POWER SUPPLY; FREQUENCY CONVERTER, PS-94-444-16

SPECIAL FEATURES: VOLTAGE REANGE 115/200 VRMS PORM 10%; 3-PHASE, WYE, GROUNDED NEUTRAL; 30 TO 600 HZ; OVER/UNDER VOLTAGE, LOSS OF PHASE, AND OVERCURRENT; PHASE ROTATION IS ANY; MODEL NO. PS-94-444-16

Weight and Dimensions

National Stock Number

Box Weight	Box Size	Item Weight	Item Dimensions	FSC	FSG	NIIN	INC
--		--	--	6130	61	01-574-2571 / 015742571	00329

National Motor Freight / Schedule B

NMFC	Description	Schedule B
116030	MACHINES ETC DATA PROCESSING	

U10025

Nonrechargeable Battery

END ITEM IDENTIFICATION:	MIDS-LVT
AMPERE HOUR CAPACITY:	2.00
BATTERY ELECTROLYTE:	LITHIUM
CONTACT QUANTITY:	2
OVERALL DIAMETER:	26.0 MILLIMETERS NOMINAL
SHAPE:	CYLINDRICAL
OVERALL LENGTH:	52.7 MILLIMETERS NOMINAL
SPECIAL FEATURES:	HERMETIC NI-PLATED STEEL CAN
SUPPLEMENTARY FEATURES:	BATTERY COMES IN A PACKAGE OF 3
TERMINAL LOCATION:	BOTTOM AND TOP
TERMINAL QUANTITY:	2
TIME CAPACITY IN HOURS:	4.80
VOLTAGE IN VOLTS:	3.00

Weight and Dimensions

National Stock Number

Box Weight	Box Size	Item Weight	Item Dimensions	FSC	FSG	NIIN	INC
--		--	--	6135	61	01-545-6582 / 015456582	35499

National Motor Freight / Schedule B

NMFC	Description	Schedule B
060680	BATTERIES OR CELL	

5945-00-020-5213

Electromagnetic Relay

RELAYS AND SOLENOIDS NATIONAL STOCK NUMBER 5945-00-020-5213 RELAY,ELECTROMAGNETIC.

Weight and Dimensions

National Stock Number

Box Weight	Box Size	Item Weight	Item Dimensions	FSC	FSG	NIIN	INC
1.2lbs	30 X 30 X 25	--	--	5945	59	00-020-5213 / 000205213	32512

National Motor Freight / Schedule B

NMFC	Description	Schedule B
061300	CIRCUIT BREAKER/SWITCH	8536410050 / Relays, electromechanical, for a voltage not exceeding 60 v

CJ70CTL-305

Electrical Receptacle Connector

CONNECTORS, ELECTRICAL NATIONAL STOCK NUMBER 5935-01-541-5518 CONNECTOR,RECEPTACLE,ELECTRICAL.

National Stock Number

FSC	FSG	NIIN	INC
5935	59	01-541-5518 / 015415518	15093

M 2 4 5 5 8 / 8 - 4 4 6

Terminal Box

CRITICALITY CODE JUSTIFICATION: ZZZW

DEPARTURE FROM CITED DOCUMENT: MATERIAL WILL BE IN ACCORDANCE WITH SHIPS PARTS CONTROL CENTER ACTIVITY HX QUALITY CONTROL,MANUFACTURING AND TESTING SPECIFICATIONS

MATERIAL: COPPER ALLOY

OVERALL DEPTH: 7.625 INCHES NOMINAL

OVERALL HEIGHT: 16.375 INCHES NOMINAL

OVERALL WIDTH: 13.375 INCHES NOMINAL

STYLE DESIGNATOR: RECTANGULAR, SURFACE MOUNTING

Weight and Dimensions

National Stock Number

Box Weight	Box Size	Item Weight	Item Dimensions	FSC	FSG	NIIN	INC
7.0lbs	--	--	--	5940	59	01-246-0848 / 012460848	00452

National Motor Freight / Schedule B

NMFC	Description	Schedule B
061700	ELEC APPLIANCES/INSTRUMENTS	8536908085 / Electrical apparatus for switching or protecting electrical circuits, or for making connection to/ in electrical circuits,for a voltage It=1000v,nesoi

700-0180-120-c

Power Supply

CONVERTERS, ELECTRICAL, NONROTATING NATIONAL STOCK NUMBER 6130-01-612-4138 POWER SUPPLY.

Weight and Dimensions

National Stock Number

Box Weight	Box Size	Item Weight	Item Dimensions	FSC	FSG	NIIN	INC
--	28 X 25 X 19	.1lbs	22 X 22 X 15	6130	61	01-612-4138 / 016124138	00740

National Motor Freight / Schedule B

NMFC	Description	Schedule B
062900	RECTIFIERS/BATTERY ELIMINATORS	

VME-1182A-060000

Circuit Card Assembly

END ITEM IDENTIFICATION:

OL-653(V)6/SSN-6(V)IOC, REAL TIME SUBSYSTEM;RGD4-13466(61081) LHD-8, CARD RACK ASSEMBLY

III PART NAME ASSIGNED BY CONTROLLING AGENCY:

64 CHANNEL BUFFER BOARD

Weight and Dimensions

National Stock Number

Box Weight	Box Size	Item Weight	Item Dimensions	FSC	FSG	NIIN	INC
--	--	--	--	5998	59	01-535-2447 / 015352447	61638

National Motor Freight / Schedule B

NMFC	Description	Schedule B
061045	BOARDS PRINTED CIRCUIT ELEC	8542900000 / Electronic integrated circuits and microassembly parts

CP-01816

Antenna

ANTENNAS, WAVEGUIDES, AND RELATED EQUIPMENT NATIONAL STOCK NUMBER 5985-01-240-8668 ANTENNA.

Weight and Dimensions

National Stock Number

Box Weight	Box Size	Item Weight	Item Dimensions	FSC	FSG	NIIN	INC
--	--	--	--	5985	59	01-240-8668 / 012408668	00749

National Motor Freight / Schedule B

NMFC	Description	Schedule B
060560	AERIALS/ANTENNAE O/T TV	9803200000 / Military equipments not identified by kind

TT-342

Electrical Insulation Tape

ELECTRICAL INSULATORS AND INSULATING MATERIALS NATIONAL STOCK NUMBER 5970-01-305-6272 TAPE,INSULATION,ELECTRICAL.

National Stock Number

FSC	FSG	NIIN	INC
5970	59	01-305-6272 / 013056272	33476

889AS251KDS

Film Fixed Resistor

ELECTRICAL RESISTANCE:	2.500 KILOHMS
BODY DIAMETER:	1.000 INCHES NOMINAL
BODY LENGTH:	12.000 INCHES NOMINAL
INCLOSURE METHOD:	ENCAPSULATED
RELIABILITY INDICATOR:	NOT ESTABLISHED
RESISTANCE TOLERANCE IN PERCENT:	-10.000/+10.000
POWER DISSIPATION RATING IN WATTS:	100.000 FREE AIR
STYLE DESIGNATOR:	AXIAL TERMINAL EACH END
TERMINAL LENGTH:	0.880 INCHES NOMINAL
TERMINAL TYPE:	FERRULE

National Stock Number

FSC	FSG	NIIN	INC
5905	59	01-293-9663 / 012939663	05311

11455030-3

Radio Frequency Cable Assembly

ELECTRICAL RESISTANCE:	51.00 OHMS IMPEDANCE
CONDUCTOR ARRANGEMENT AND QUANTITY:	1 COAXIAL
CONDUCTOR FORM:	STRANDED SINGLE CONDUCTOR
CROSS SECTION OUTSIDE DIAMETER:	0.425 INCHES NOMINAL
CROSS-SECTIONAL SHAPE STYLE:	ROUND
III CONDUCTOR QUANTITY:	1
MATERIAL:	COPPER ALLOY 1ST POSITION CONDUCTOR SINGLE CONDUCTOR
MATERIAL:	SILVER 2ND POSITION CONDUCTOR SINGLE CONDUCTOR
OVERALL LENGTH:	36.000 INCHES
MATERIAL DOCUMENT AND CLASSIFICATION:	MIL-C-17 MIL SPEC ALL MATERIAL RESPONSES 1ST POSITION CONDUCTOR ALL CONDUCTORS
ROUND CONDUCTOR SIZE:	12 AWG SINGLE CONDUCTOR
STRAND AWG SIZE PER CONDUCTOR:	21 SINGLE CONDUCTOR
STRAND QUANTITY PER CONDUCTOR:	7 SINGLE CONDUCTOR
STYLE DESIGNATOR:	INTERNAL CONNECTORS
SURFACE TREATMENT:	COPPER CORE CONDUCTOR SINGLE CONDUCTOR AND SILVER CORE CONDUCTOR SINGLE CONDUCTOR
TERMINAL COMMERCIAL AND GOVERNMENT ENTITY CODE:	81349 BOTH ENDS SINGLE CONDUCTOR
TERMINAL MANUFACTURER IDENTIFYING REFERENCE NUMBER:	M39012/01-0005 1ST END SINGLE CONDUCTOR

Weight and Dimensions

Box Weight	Box Size	Item Weight	Item Dimensions
.7lbs	--	--	--

National Motor Freight / Schedule B

NMFC	Description	Schedule B
------	-------------	------------

061130

CABLE
ASSEMBLY

9030400000 / Other instruments and apparatus, specially
designed for telecommunications (for example, cross-talk
meters, gain measuring instruments etc)

National Stock Number

FSC	FSG	NIIN	INC
5995	59	01-207-2746 / 012072746	00886

901167-2

Antenna

END ITEM IDENTIFICATION:

USED ON DASSAULT FALCON 900 FRENCH CORPORATE JET AIRCRAFT

SPECIAL FEATURES:

SATCOM ANTENNA, WIRELESS ACCESS POINT

National Stock Number

FSC	FSG	NIIN	INC
5985	59	01-582-9828 / 015829828	00749

FS4012D/AA

Electrical Contact

END ITEM IDENTIFICATION:

MATCAL5

PART NAME ASSIGNED BY CONTROLLING AGENCY:

ITEM NAME:CONTACT,ELECTRICAL

SPECIAL FEATURES:

FS4012D/AA,SK6962

Weight and Dimensions

National Stock Number

Box Weight	Box Size	Item Weight	Item Dimensions	FSC	FSG	NIIN	INC
--	--	--	--	5999	59	01-610-3061 / 016103061	00443

National Motor Freight / Schedule B

NMFC	Description	Schedule B
061300	CIRCUIT BREAKER/SWITCH	

S2831FM7216-R

Electrical Connector Backshell

BODY ANGLE IN DEG: 90.0
FEATURES PROVIDED: ELECTROMAGNETIC INTERFERENCE SHIELDING
SPECIAL FEATURES: THE BACKSHELL HAS RFI SHIELDING AND MATES TO A M38999 SERIES III CONNECTOR.
STYLE DESIGNATOR: ANGLE SHAPE SPLIT TYPE

Weight and Dimensions

National Stock Number

Box Weight	Box Size	Item Weight	Item Dimensions	FSC	FSG	NIIN	INC
--	60 X 164 X 324	--	40 X 144 X 304	5935	59	01-600-9519 / 016009519	67169

National Motor Freight / Schedule B

NMFC	Description	Schedule B
061680	ELEC WIRING PLUGS ETC	

19590

Voltage Regulator

CIRCUIT TYPE:	PARALLEL OR SERIES
COMPENSATION PROVIDED:	INDIVIDUAL DROOP
OUTPUT VOLTAGE RATING IN VOLTS:	12.0 MINIMUM AND 208.0 MAXIMUM
OUTPUT CURRENT TYPE:	AC
INPUT PHASE:	THREE
INPUT VOLTAGE RATING IN VOLTS:	120.0 MINIMUM AND 208.0 MAXIMUM
INPUT CURRENT TYPE:	AC
INPUT FREQUENCY RATING IN HERTZ:	400.0 NOMINAL
REGULATION METHOD:	ELECTROMAGNETIC
REGULATION PERCENT:	0.50

Weight and Dimensions

Box Weight	Box Size	Item Weight	Item Dimensions	FSC	FSG	NIIN	INC
4.0lbs	--	--	--	6110	61	01-383-4122 / 013834122	00176

National Stock Number

National Motor Freight / Schedule B

NMFC	Description	Schedule B
062920	REGULATORS INDUCTION/VOLTAGE	8543909000 / Electrical machines and apparatus parts

4610

Electron Tube

TUBE TYPE:

TRIODE

Weight and Dimensions

National Stock Number

Box Weight	Box Size	Item Weight	Item Dimensions	FSC	FSG	NIIN	INC
2.0lbs	--	--	--	5960	59	00-010-5300 / 000105300	00001

National Motor Freight / Schedule B

NMFC	Description	Schedule B
063476	TUBES	8540890020 / Gas and vapor electron tubes

RF-2601/AC

Antenna Coupler

ANTENNAS, WAVEGUIDES, AND RELATED EQUIPMENT NATIONAL STOCK NUMBER 5985-00-134-1526 COUPLER,ANTENNA.

Weight and Dimensions

National Stock Number

Box Weight	Box Size	Item Weight	Item Dimensions	FSC	FSG	NIIN	INC
85.7lbs	280 X 200 X 200	--	--	5985	59	00-134-1526 / 001341526	16118

National Motor Freight / Schedule B

NMFC	Description	Schedule B
061700	ELEC APPLIANCES/INSTRUMENTS	8529109000 / Antenna & antenna reflectors of all kinds; parts suitable for use soley or principally w/ apparatus of heading 8525 to 8528

11455197-1

Radio Frequency Cable Assembly

CABLE, CORD, AND WIRE ASSEMBLIES: COMMUNICATION EQUIPMENT NATIONAL STOCK NUMBER 5995-01-209-5198 CABLE ASSEMBLY,RADIO FREQUENCY.

Weight and Dimensions

National Stock Number

Box Weight	Box Size	Item Weight	Item Dimensions	FSC	FSG	NIIN	INC
.1lbs	120	--	--	5995	59	01-209-5198 / 012095198	00886

National Motor Freight / Schedule B

NMFC	Description	Schedule B
061130	CABLE ASSEMBLY	9030400000 / Other instruments and apparatus, specially designed for telecommunications (for examle, cross-talk meters, gain measuring instruments etc)

11455137

Radio Frequency Cable Assembly

ELECTRICAL RESISTANCE:	50.00 OHMS IMPEDANCE
CONDUCTOR ARRANGEMENT AND QUANTITY:	1 COAXIAL
CONDUCTOR FORM:	STRANDED SINGLE CONDUCTOR
III CONDUCTOR QUANTITY:	1
MATERIAL DOCUMENT AND CLASSIFICATION:	QQ-W-343 FED SPEC SINGLE MATERIAL RESPONSE CORE CONDUCTOR SINGLE CONDUCTOR
MATERIAL:	COPPER CORE CONDUCTOR SINGLE CONDUCTOR
MATERIAL:	PLASTIC POLYVINYL CHLORIDE 1ST POSITION JACKET CABLE
OVERALL LENGTH:	71.000 INCHES
ROUND CONDUCTOR SIZE:	19 AWG SINGLE CONDUCTOR
STRAND AWG SIZE PER CONDUCTOR:	20 SINGLE CONDUCTOR
STRAND QUANTITY PER CONDUCTOR:	33 SINGLE CONDUCTOR
SURFACE TREATMENT:	TIN CORE CONDUCTOR SINGLE CONDUCTOR

Weight and Dimensions

National Stock Number

Box Weight	Box Size	Item Weight	Item Dimensions	FSC	FSG	NIIN	INC
.3lbs	710	--	--	5995	59	01-208-2453 / 012082453	00886

National Motor Freight / Schedule B

NMFC	Description	Schedule B
061130	CABLE ASSEMBLY	9030400000 / Other instruments and apparatus, specially designed for telecommunications (for examle, cross-talk meters, gain measuring instruments etc)

9201-CA

Microphone Element

ELEMENT TYPE:	DYNAMIC
END ITEM IDENTIFICATION:	HGU-56/P AIRCREW INTEGRATED HELMET, ALL SIZES
BODY STYLE:	IRREGULAR SHAPE
DEPARTURE FROM CITED DOCUMENT:	DOES NOT INCLUDE BOOM OR CORD ASSEMBLY
FREQUENCY RESPONSE RANGE IN HERTZ:	+200.0/+6000.0
HEIGHT:	0.690 INCHES NOMINAL
NOISE CANCELING FEATURE:	INCLUDED
IMPEDANCE RATING:	5.0 OHMS NOMINAL
LENGTH:	2.380 INCHES NOMINAL
SHOCK MOUNT:	NOT PROVIDED
SOUND PICKUP DIRECTIONAL TYPE:	NOT RATED
POLARITY CONNECTION:	NOT REQUIRED
SPECIFICATION/STANDARD DATA:	81349-MILIMI26542/11 GOVERNMENT SPECIFICATION
WIDTH:	1.000 INCHES NOMINAL
TERMINAL TYPE:	PIN JACK

Weight and Dimensions

National Stock Number

Box Weight	Box Size	Item Weight	Item Dimensions	FSC	FSG	NIIN	INC
.1lbs	--	--	--	5965	59	01-391-1703 / 013911703	00293

National Motor Freight / Schedule B

NMFC	Description	Schedule B
062820	RADIO/TV TRANSMIT/RECEIVE SETS	8518903000 / Microphone parts, loudspeaker parts, amplifier parts & headphone parts

11455139

B Radio Frequency Cable Assembly

SPECIAL FEATURES:

71.000 IN.LG

Weight and Dimensions

National Stock Number

Box Weight	Box Size	Item Weight	Item Dimensions	FSC	FSG	NIIN	INC
.6lbs	710	--	--	5995	59	01-172-7596 / 011727596	60147

National Motor Freight / Schedule B

NMFC	Description	Schedule B
061130	CABLE ASSEMBLY	9030400000 / Other instruments and apparatus, specially designed for telecommunications (for examle, cross-talk meters, gain measuring instruments etc)

11467148

Fixed Attenuator

APPLICATION DESIGN:	TRANSMISSION LINE
ATTENUATION ACCURACY IN DECIBELS:	-0.10/+0.10
BODY MATERIAL:	METAL
BODY STYLE:	ROUND, TERMINAL/TERMINALS IN OPPOSITE SURFACE
BODY SURFACE TREATMENT:	ANY ACCEPTABLE
COAXIAL CONNECTOR SERIES DESIGNATION:	N
FSC APPLICATION DATA:	ANTENNAS,WAVEGUIDES,AND RELATED EQUIPMENT
MOUNTING METHOD:	CONNECTOR
OUTPUT IMPEDANCE RATING IN OHMS:	50.0
OVERALL DIAMETER:	0.760 INCHES MAXIMUM
INPUT IMPEDANCE RATING IN OHMS:	50.0
RF SIGNAL ATTENUATION IN DECIBELS:	32.0
OVERALL LENGTH:	2.750 INCHES MAXIMUM
POWER RATING:	5.0 WATTS AVERAGE AND 1.0 KILOWATTS PEAK
VOLTAGE STANDING WAVE RATIO:	1.20
TERMINAL TYPE AND QUANTITY:	2 CONNECTOR

Weight and Dimensions

National Stock Number

Box Weight	Box Size	Item Weight	Item Dimensions	FSC	FSG	NIIN	INC
.4lbs	--	--	--	5985	59	01-254-1603 / 012541603	14224

National Motor Freight / Schedule B

NMFC	Description	Schedule B
060535	AERIAL/ANTENNAS DIRECTIONAL	8529109000 / Antenna & antenna reflectors of all kinds; parts suitable for use solely or principally w/ apparatus of heading 8525 to 8528

MIS-29556/5

Connector Adapter

BODY STYLE:	STRAIGHT SHAPE, INTERNAL COUPLING
MATING END QUANTITY:	2
OVERALL DIAMETER:	0.593 INCHES MAXIMUM
OVERALL LENGTH:	1.677 INCHES MAXIMUM

Weight and Dimensions

National Stock Number

Box Weight	Box Size	Item Weight	Item Dimensions	FSC	FSG	NIIN	INC
.1lbs	--	--	--	5935	59	01-169-3096 / 011693096	15091

National Motor Freight / Schedule B

NMFC	Description	Schedule B
061680	ELEC WIRING PLUGS ETC	8548900100 / Electrical parts of machinery or apparatus not specified or included elsewhere in chapter 85

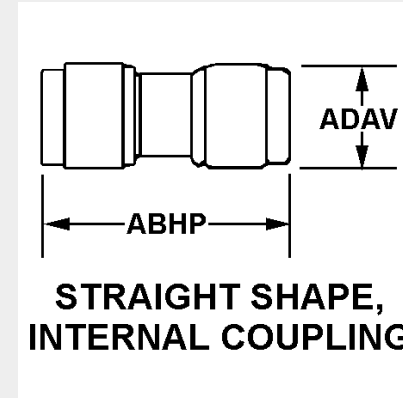

TI7000-006

Battery Power Supply

BATTERY QUANTITY:

2

END ITEM IDENTIFICATION:

TI1000GPU-24

PART NAME ASSIGNED BY CONTROLLING AGENCY:

CELLS/BATTERIES

SPECIAL FEATURES:

SEALED DRY CELLS

National Stock Number

FSC	FSG	NIIN	INC
6130	61	01-501-0422 / 015010422	11106

PSA-50200-LP/1211

Antenna

ANTENNAS, WAVEGUIDES, AND RELATED EQUIPMENT NATIONAL STOCK NUMBER 5985-01-642-4707 ANTENNA.

National Stock Number

FSC	FSG	NIIN	INC
5985	59	01-642-4707 / 016424707	00749

HS6206G48BN

Electrical Plug Connector

END ITEM IDENTIFICATION:

7-610000000-1

Weight and Dimensions

National Stock Number

Box Weight	Box Size	Item Weight	Item Dimensions	FSC	FSG	NIIN	INC
--	--	--	--	5935	59	01-616-1916 / 016161916	01938

National Motor Freight / Schedule B

NMFC	Description	Schedule B
061680	ELEC WIRING PLUGS ETC	

1DGTKSDX01

E Special Purpose Cable Assembly

ACCESSORY WIRE TYPE AND QUANTITY: 1 GROUND
CONDUCTOR CROSS-SECTIONAL SHAPE: TUBULAR BRAID ALL CONDUCTORS
CONDUCTOR FORM: STRANDED ALL CONDUCTORS
CONDUCTOR QUANTITY: 8
MATERIAL: COPPER 1ST POSITION PRIMARY INSULATION ALL CONDUCTORS
MATERIAL: COPPER CORE CONDUCTOR ALL CONDUCTORS
MATERIAL: PLASTIC 2ND POSITION JACKET ALL CONDUCTORS
ROUND CONDUCTOR SIZE: 24 AWG ALL CONDUCTORS
STRAND AWG SIZE PER CONDUCTOR: 32 ALL CONDUCTORS
STRAND QUANTITY PER CONDUCTOR: 7 ALL CONDUCTORS
STYLE DESIGNATOR: INTERNAL CONNECTORS
TEMP RATING: 0.0 DEG CELSIUS AND 50.0 DEG CELSIUS
TERMINAL COMMERCIAL AND GOVERNMENT ENTITY CODE: 1VPW8 BOTH ENDS ALL CONDUCTORS
TERMINAL MANUFACTURER IDENTIFYING REFERENCE NUMBER: 747912-2 2ND END ALL CONDUCTORS
TERMINAL MANUFACTURER IDENTIFYING REFERENCE NUMBER: 747904-2 1ST END ALL CONDUCTORS
TERMINATION TYPE: CONNECTOR INTERNAL STRAIGHT BOTH ENDS ALL CONDUCTORS

National Stock Number

FSC	FSG	NIIN	INC
5995	59	01-526-2629 / 015262629	00782

A 6 6 2 - 1 - R 1 7 2

Electromagnetic Relay

DUTY TYPE:	CONTINUOUS
CENTER TO CENTER DISTANCE BETWEEN MOUNTING FACILITIES PARALLEL TO LENGTH:	1.437 INCHES NOMINAL SINGLE MOUNTING FACILITY
COIL QUANTITY:	1
ENVIRONMENTAL PROTECTION:	HERMETIC
FEATURES PROVIDED:	POLARIZED
MOUNTING FACILITY TYPE AND QUANTITY:	2 UNTHREADED HOLE SINGLE MOUNTING FACILITY
MOUNTING FACILITY PATTERN:	IN-LINE SINGLE MOUNTING FACILITY
NOMINAL OPERATING CURRENT RATING AND TYPE:	80.0 MILLIAMPERES DC SINGLE WINDING
OPERATING VOLTAGE RATING AND TYPE AT SPECIFIED TEMP:	28.0 VOLTS DC 25 DEG CELSIUS SINGLE WINDING
OVERALL HEIGHT:	2.313 INCHES MAXIMUM
MAIN CONTACT LOAD CURRENT RATING AT MAXIMUM RATED VOLTAGE:	3.0 AMPERES DC RESISTIVE LOAD
OVERALL LENGTH:	2.000 INCHES MAXIMUM
OVERALL WIDTH:	1.500 INCHES MAXIMUM
PILE-UP MAIN CONTACT FORM ARRANGEMENT:	DPDT
WINDING QUANTITY:	1
TERMINAL TYPE AND QUANTITY:	8 WIRE HOOK ALL FUNCTIONS
TIME DELAY:	1.00 SECONDS NOMINAL FIXED OPERATE TIME

Weight and Dimensions

National Stock Number

Box Weight	Box Size	Item Weight	Item Dimensions	FSC	FSG	NIIN	INC
.2lbs	--	--	--	5945	59	00-052-9823 / 000529823	32512

National Motor Freight / Schedule B

NMFC	Description	Schedule B
061300	CIRCUIT BREAKER/SWITCH	

35-55-0827-00

Diplexer

END ITEM IDENTIFICATION:

BOAT,RIVERINE ASSAULT 33FT

SPECIAL FEATURES:

END ITEM:LP-DFD DUAL FEED DIPLEXER

Weight and Dimensions

National Stock Number

Box Weight	Box Size	Item Weight	Item Dimensions	FSC	FSG	NIIN	INC
--	57 X 30	--	--	5985	59	01-567-9136 / 015679136	29718

National Motor Freight / Schedule B

NMFC	Description	Schedule B
060535	AERIAL/ANTENNAS DIRECTIONAL	

RW47V104

Fixed Wire Wound Induct Resistor

AMBIENT TEMP IN DEG CELSIUS AT FULL RATED POWER:	25.0
AMBIENT TEMP IN DEG CELSIUS AT ZERO PERCENT RATED POWER:	350.0
BODY DIAMETER:	1.312 INCHES MAXIMUM
BODY LENGTH:	10.438 INCHES MINIMUM AND 10.562 INCHES MAXIMUM
CUBIC MEASURE:	14.279 CUBIC INCHES
III ELECTRICAL RESISTANCE:	100.000 KILOHMS
INCLOSURE METHOD:	ENCAPSULATED
RELIABILITY INDICATOR:	NOT ESTABLISHED
RESISTANCE TOLERANCE IN PERCENT:	-5.000/+5.000
POWER DISSIPATION RATING IN WATTS:	210.000 FREE AIR
SPECIFICATION/STANDARD DATA:	81349-MIL-R-26/3 GOVERNMENT SPECIFICATION
STYLE DESIGNATOR:	RADIAL TERMINAL EACH END
TEMP RANGE OF TEMP COEFFICIENT IN DEG CELSIUS:	-55.0/+350.0
TEMP COEFFICIENT OF RESISTANCE IN PPM PER DEG CELSIUS:	-260.0/+260.0
TERMINAL LENGTH:	0.563 INCHES NOMINAL
TERMINAL TYPE:	TAB, SOLDER LUG
TERMINAL WIDTH:	0.172 INCHES MINIMUM AND 0.328 INCHES MAXIMUM

Weight and Dimensions

National Stock Number

Box Weight	Box Size	Item Weight	Item Dimensions	FSC	FSG	NIIN	INC
.4lbs	--	--	--	5905	59	00-837-3613 / 008373613	37403

National Motor Freight / Schedule B

NMFC	Description	Schedule B
062960	REOSTATS/PARTS	8533390080 / Wirewound variable resistors

I017-003743480V

Circuit Card Assembly

SPECIAL FEATURES:

FUSE 9,PRINTED WIRING BOARD 1,RESISTOR 2,TRANSFORMER 6

Weight and Dimensions

National Stock Number

Box Weight	Box Size	Item Weight	Item Dimensions	FSC	FSG	NIIN	INC
4.0lbs	--	--	--	5998	59	01-334-0717 / 013340717	61638

National Motor Freight / Schedule B

NMFC	Description	Schedule B
061045	BOARDS PRINTED CIRCUIT ELEC	8542900000 / Electronic integrated circuits and microassembly parts

DTD-175D-02

Electrical Equipment Rack

CRITICALITY CODE JUSTIFICATION: FEAT
OVERALL DEPTH: 22.000 INCHES MINIMUM AND 32.000 INCHES MAXIMUM
OVERALL HEIGHT: 2.625 INCHES NOMINAL
OVERALL WIDTH: 19.000 INCHES NOMINAL
PART NAME ASSIGNED BY CONTROLLING AGENCY: DUAL KG-175D (TACLANE-MICRO),DTD-175D-XX,RUGGED RACK MOUNT ENCLOSURE
SPECIAL FEATURES: SUPPORTS KG-175 (2 EACH) WITH REDUCDANT POWER SUPPLY;WEIGHT:7.000 POUNDS;OPERATING TEMPERATURE RATING:MINUS 30.0C TO 60.0C;POWER:90-264VAC,47-63,400HZ STANDARD;12,28,48VDC OPTIONAL

National Stock Number

FSC	FSG	NIIN	INC
5975	59	01-586-4585 / 015864585	06353

OL-TR3-20

Rackmount Frame

END ITEM IDENTIFICATION: TRE SERIES AMPLITUDE/SLOPE EQUALIZER SYSTEMS
OVERALL HEIGHT: 1.750 INCHES NOMINAL
OVERALL LENGTH: 20.000 INCHES NOMINAL
OVERALL WIDTH: 19.000 INCHES NOMINAL

National Stock Number

FSC	FSG	NIIN	INC
5996	59	01-616-4662 / 016164662	77777

3700089-302

Alternating Current Motor

FUNCTIONAL DESCRIPTION: USED ON FLOW PUMP ASSEMBLY
ROTOR SPEED RATING IN RPM: 2850.0 LOW FULL LOAD AND 3450.0 HIGH FULL LOAD
PHASE: THREE OUTPUT
POWER RATING: 1.500 HORSEPOWER OUTPUT
SPECIAL FEATURES: PART IS TOTALLY ENCLOSED, FAN COOLED (TEFC); 1 UNIT PER ASSEMBLY

National Stock Number

FSC	FSG	NIIN	INC
6105	61	01-481-1337 / 014811337	00530

11459590-2

Radio Frequency Cable Assembly

CROSS-SECTIONAL SHAPE STYLE: ROUND
III CONDUCTOR QUANTITY: 1
OVERALL LENGTH: 4.500 FEET
SPECIAL FEATURES: MARKER A,W117P1 (A35J31)
STYLE DESIGNATOR: INTERNAL CONNECTORS
TERMINATION TYPE: CONNECTOR INTERNAL STRAIGHT BOTH ENDS SINGLE CONDUCTOR

Weight and Dimensions

National Stock Number

Box Weight	Box Size	Item Weight	Item Dimensions	FSC	FSG	NIIN	INC
.3lbs	--	--	--	5995	59	01-106-2032 / 011062032	00886

National Motor Freight / Schedule B

NMFC	Description	Schedule B
061130	CABLE ASSEMBLY	9030400000 / Other instruments and apparatus, specially designed for telecommunications (for examle, cross-talk meters, gain measuring instruments etc)



11454906-1

Radio Frequency Cable Assembly

III CONDUCTOR QUANTITY: 1
OVERALL LENGTH: 12.000 INCHES
STYLE DESIGNATOR: INTERNAL CONNECTORS

Weight and Dimensions

National Stock Number

Box Weight	Box Size	Item Weight	Item Dimensions	FSC	FSG	NIIN	INC
.2lbs	--	--	--	5995	59	01-207-8959 / 012078959	00886

National Motor Freight / Schedule B

NMFC	Description	Schedule B
061130	CABLE ASSEMBLY	9030400000 / Other instruments and apparatus, specially designed for telecommunications (for examle, cross-talk meters, gain measuring instruments etc)

2916360

Electrical Box Connector

MATERIAL: ALUMINUM ALLOY 6061
SPECIAL FEATURES: 125 MICROINCH OVERALL
SURFACE TREATMENT: CHEMICAL FILMS

Weight and Dimensions

National Stock Number

Box Weight	Box Size	Item Weight	Item Dimensions	FSC	FSG	NIIN	INC
.1lbs	--	--	--	5975	59	01-289-5972 / 012895972	09663

National Motor Freight / Schedule B

NMFC	Description	Schedule B
060500	ELECTRICAL EQUIPMENT GROUP	8543909000 / Electrical machines and apparatus parts

11455196-1

Radio Frequency Cable Assembly

CABLE, CORD, AND WIRE ASSEMBLIES: COMMUNICATION EQUIPMENT NATIONAL STOCK NUMBER 5995-01-208-2454 CABLE ASSEMBLY,RADIO FREQUENCY.

Weight and Dimensions

National Stock Number

Box Weight	Box Size	Item Weight	Item Dimensions	FSC	FSG	NIIN	INC
--	--	--	--	5995	59	01-208-2454 / 012082454	00886

National Motor Freight / Schedule B

NMFC	Description	Schedule B
061130	CABLE ASSEMBLY	9030400000 / Other instruments and apparatus, specially designed for telecommunications (for examle, cross-talk meters, gain measuring instruments etc)

VD4802-99-1020

Interior Cable Rack

CLEARANCE WIDTH: 1.200 INCHES NOMINAL
MATERIAL: STEEL
MOUNTING FACILITY QUANTITY: 4
MOUNTING PROVISION: BRACKET
OVERALL HEIGHT: 1.500 INCHES NOMINAL
OVERALL LENGTH: 15.550 INCHES NOMINAL
SPECIAL FEATURES: MODIFIED MODEL D-329 P/N VD4802-00-0000, INCLUDES PLASTIC/NYLON HINGE AND 2 QUICK RELEASE PINS. 1 ARM 15.550 INCHES LONG, 2ND ARM 13.000 INCHES LONG
STYLE DESIGNATOR: BRACKET TYPE
SURFACE TREATMENT: ZINC

National Stock Number

FSC	FSG	NIIN	INC
5975	59	01-595-4951 / 015954951	08082

6500671

Storage Battery

END ITEM IDENTIFICATION:

TEST

SPECIAL FEATURES:

RECHARGEABLE LI-ION BATTERY MODEL 3UR18650F-2-QC-OA1 - GATEWAY LAPTOP 450SX4

National Stock Number

FSC	FSG	NIIN	INC
6140	61	01-547-8542 / 015478542	00013

9473

Variable Wire Wound Pre Resistor

ELECTRICAL RESISTANCE PER SECTION:	2.0 KILOHMS SINGLE SECTION
ACTUATOR TYPE:	DOUBLE ENDED SHAFT
BODY HEIGHT:	0.295 INCHES MINIMUM AND 0.325 INCHES MAXIMUM
BODY LENGTH:	1.236 INCHES MINIMUM AND 1.265 INCHES MAXIMUM
BODY WIDTH:	0.265 INCHES MINIMUM AND 0.295 INCHES MAXIMUM
BODY STYLE:	RECTANGULAR W/MOUNTING HOLES/SLOTS
MOUNTING FACILITY QUANTITY:	2
MOUNTING METHOD:	UNTHREADED HOLE
LATERAL DISTANCE BETWEEN MOUNTING HOLE CENTERS:	0.996 INCHES MINIMUM AND 1.005 INCHES MAXIMUM
RELIABILITY INDICATOR:	NOT ESTABLISHED
SECTION QUANTITY:	1
SHAFT DIAMETER:	0.081 INCHES MINIMUM AND 0.086 INCHES MAXIMUM
SHAFT LENGTH:	0.380 INCHES MINIMUM
SHAFT STYLE:	ROUND
POWER DISSIPATION RATING PER SECTION IN WATTS:	0.2 FREE AIR SINGLE SECTION
TERMINAL LOCATION:	REAR END
TERMINAL TYPE AND QUANTITY:	3 WIRE LEAD

Weight and Dimensions

National Stock Number

Box Weight	Box Size	Item Weight	Item Dimensions	FSC	FSG	NIIN	INC
.1lbs	--	--	--	5905	59	00-156-6537 / 001566537	37408

National Motor Freight / Schedule B

NMFC	Description	Schedule B
062960	REOSTATS/PARTS	8533390080 / Wirewound variable resistors

SQ11-050

Power Supply

ENVIRONMENTAL PROTECTION:	HERMETICALLY SEALED
FEATURES PROVIDED:	INPUT FILTER AND OUTPUT FILTER
OPERATING AMBIENT TEMP RANGE:	-25.0/+71.0 DEG CELSIUS
OUTPUT PHASE:	SINGLE SINGLE POWER OUTPUT
OUTPUT CURRENT RATING:	500.0 DC MILLIAMPERES NOMINAL SINGLE POWER OUTPUT
OUTPUT VOLTAGE RATING:	5.0 DC VOLTS NOMINAL 1ST POWER OUTPUT
OVERALL HEIGHT:	1.250 INCHES NOMINAL
INPUT PHASE:	SINGLE SINGLE OPERATING POWER RQMT
INPUT VOLTAGE RATING:	105.0 AC POUNDS PER HOUR DRY SINGLE OPERATING POWER RQMT AND 125.0 AC POUNDS PER HOUR WITH RETAINING CHAIN SINGLE OPERATING POWER RQMT
INPUT FREQUENCY RATING:	50.0 HERTZ MINIMUM SINGLE OPERATING POWER RQMT AND 440.0 HERTZ MAXIMUM SINGLE OPERATING POWER RQMT
OVERALL LENGTH:	2.500 INCHES NOMINAL
OVERALL WIDTH:	2.300 INCHES NOMINAL

National Stock Number

FSC	FSG	NIIN	INC
6130	61	01-172-8845 / 011728845	00740

SQ11-020

Power Supply

ELECTRICAL POWER SOURCE RELATIONSHIP: OPERATING
OPERATING AMBIENT TEMP RANGE: -25.0/+71.0 DEG CELSIUS
OUTPUT CONNECTION QUANTITY: 2 SINGLE POWER OUTPUT
OUTPUT CONNECTION TYPE: SOLDER POST SINGLE POWER OUTPUT
OUTPUT CURRENT RATING: 200.0 DC MILLIAMPERES NOMINAL SINGLE POWER OUTPUT
OUTPUT VOLTAGE RATING: 5.0 DC VOLTS NOMINAL SINGLE POWER OUTPUT
INPUT CONNECTION QUANTITY: 2 SINGLE OPERATING POWER RQMT
INPUT CONNECTION TYPE: SOLDER POST SINGLE OPERATING POWER RQMT
INPUT VOLTAGE RATING: 105.0 AC POUNDS PER HOUR DRY SINGLE OPERATING POWER RQMT AND 125.0 AC POUNDS PER HOUR WITH RETAINING CHAIN SINGLE OPERATING POWER RQMT
INPUT FREQUENCY RATING: 50.0 HERTZ MINIMUM SINGLE OPERATING POWER RQMT AND 440.0 HERTZ MAXIMUM SINGLE OPERATING POWER RQMT

National Stock Number

FSC	FSG	NIIN	INC
6130	61	01-474-6896 / 014746896	00740

FXLM-38-10

Electrical Cable Protector

END ITEM IDENTIFICATION: LOADER,SCOOP TYPE
BODY OUTSIDE DIAMETER: 0.63 INCHES NOMINAL
FLEXIBILITY: FLEXIBLE
MATERIAL: PLASTIC BODY
OPENING INSIDE DIAMETER: 0.38 INCHES NOMINAL
PART NAME ASSIGNED BY CONTROLLING AGENCY: PROTECTOR,ELECTRICAL CABLE

National Motor Freight / Schedule B

National Stock Number

NMFC	Description	Schedule B	FSC	FSG	NIIN	INC
160310	PROTECTORS CABLE GROUND/GUY WIRE		5975	59	01-625-4670 / 016254670	00111

51587

Electrical Insulation Tape

ADHESIVE LOCATION:	ONE SIDE
ADHESIVE TYPE:	PRESSURE SENSITIVE
COLOR:	BLACK OVERALL
CUT TYPE AND QUANTITY:	1 SINGLE
DEPARTURE FROM CITED DESIGNATOR:	AS MODIFIED BY COLOR
DIELECTRIC WITHSTANDING VOLTAGE IN VOLTS:	12000.0
MATERIAL:	PLASTIC POLYETHYLENE OVERALL
NOMINAL LENGTH:	1296.0 INCHES
NOMINAL OVERALL THICKNESS:	0.0090 INCHES
NOMINAL WIDTH:	1.000 INCHES
NONDEFINITIVE SPEC/STD DATA:	EF-9 TYPE
MATERIAL DOCUMENT AND CLASSIFICATION:	MIL-I-15126,TYPE EF-9 MIL SPEC SINGLE MATERIAL RESPONSE OVERALL

Weight and Dimensions

National Stock Number

Box Weight	Box Size	Item Weight	Item Dimensions	FSC	FSG	NIIN	INC
.5lbs		--	--	5970	59	00-583-6097 / 005836097	33476

National Motor Freight / Schedule B

NMFC	Description	Schedule B
049680	CLOTH R TAPE INSULATING	8546900000 / Electrical insulators

01-026D 286-02

Handset Handle

DIAL MOUNTING FACILITIES:

NOT INCLUDED

III END ITEM IDENTIFICATION:

BOAT,RIVERINE

PART NAME ASSIGNED BY CONTROLLING AGENCY:

MICROPHONE

SPECIAL FEATURES:

FOUR RIGHT ANGLE CONNECTOR

SWITCH MOUNTING FACILITIES:

NOT INCLUDED

Weight and Dimensions

National Stock Number

Box Weight	Box Size	Item Weight	Item Dimensions	FSC	FSG	NIIN	INC
--		--	--	5965	59	01-620-7739 / 016207739	08083

National Motor Freight / Schedule B

NMFC	Description	Schedule B
060500	ELECTRICAL EQUIPMENT GROUP	

5268-3

Electrical Insulation Sleeving

COLOR: ANY ACCEPTABLE
ENVIRONMENTAL PROTECTION: ANY ACCEPTABLE
FLEXIBILITY: RIGID
MATERIAL: PLASTIC POLYTETRAFLUOROETHYLENE
INSIDE DIAMETER: 0.289 INCHES MINIMUM AND 0.311 INCHES MAXIMUM
OVERALL LENGTH: 2.000 INCHES NOMINAL
WALL THICKNESS: 0.015 INCHES NOMINAL
STYLE DESIGNATOR: NONSHRINKABLE

National Motor Freight / Schedule B

National Stock Number

NMFC	Description	Schedule B	FSC	FSG	NIIN	INC
103300	INSULATING MATERIAL	8546900000 / Electrical insulators	5970	59	00-166-3836 / 001663836	00867

NTN1667A

Battery Charger

END ITEM IDENTIFICATION:

VERY HIGH FREQUENCY FM (VHF FM)

SPECIAL FEATURES:

NOMENCLATURE SINGLE BAY BATTERY CHARGER

National Stock Number

FSC	FSG	NIIN	INC
6130	61	01-512-5033 / 015125033	00480

NTN9857C

Storage Battery

SPECIAL FEATURES:

INAVY RADIO BATT , XTS2500 / 1500

Weight and Dimensions

National Stock Number

Box Weight	Box Size	Item Weight	Item Dimensions	FSC	FSG	NIIN	INC
--	--	--	--	6140	61	01-587-6279 / 015876279	00013

National Motor Freight / Schedule B

NMFC	Description	Schedule B
060820	BATTERY/BATTERY BOOSTER CABLES	

539-230-004-698

Earphone Retainer F

HEADSETS, HANDSETS, MICROPHONES AND SPEAKERS NATIONAL STOCK NUMBER 5965-01-411-1181 EARPHONE RETAINER F.

National Stock Number

FSC	FSG	NIIN	INC
5965	59	01-411-1181 / 014111181	77777

42-1003

Current Transformer

BODY HEIGHT:	5.438 INCHES NOMINAL
BODY LENGTH:	4.812 INCHES NOMINAL
BODY WIDTH:	2.000 INCHES NOMINAL
MOUNTING FACILITY QUANTITY:	3 SINGLE GROUP
MOUNTING HOLE DIAMETER:	0.438 INCHES NOMINAL SINGLE GROUP
MOUNTING METHOD:	UNTHREADED HOLE SINGLE GROUP
INCLOSURE TYPE:	FULLY INCLOSED
INPUT-OUTPUT PHASE RELATIONSHIP:	SINGLE PHASE TO SINGLE PHASE SINGLE COMPONENT
RELIABILITY INDICATOR:	NOT ESTABLISHED
SPECIAL FEATURES:	PRIMARY RATED BUT NOT INCLUDED
WINDING OPERATING CURRENT:	100.0 AMPERES AC MAXIMUM SINGLE COMPONENT SINGLE PRIMARY
WINDING FUNCTION AND QUANTITY:	1 SECONDARY SINGLE COMPONENT
WINDING OPERATING CURRENT:	5.0 AMPERES AC MAXIMUM SINGLE COMPONENT SINGLE SECONDARY
TERMINAL TYPE AND QUANTITY:	2 THREADED STUD

Weight and Dimensions

National Stock Number

Box Weight	Box Size	Item Weight	Item Dimensions	FSC	FSG	NIIN	INC
3.5lbs	--	--	--	5950	59	01-175-4669 / 011754669	00738

National Motor Freight / Schedule B

NMFC	Description	Schedule B
063420	TRANSFORMERS,NOI,OR TRANSFORMER PAR	

281168-1

Antenna Assembly

ANTENNAS, WAVEGUIDES, AND RELATED EQUIPMENT NATIONAL STOCK NUMBER 5985-01-595-0069 ANTENNA ASSEMBLY.

National Stock Number

FSC	FSG	NIIN	INC
5985	59	01-595-0069 / 015950069	06820

020-0830

Power Transformer

BODY HEIGHT:	2.810 INCHES MAXIMUM
BODY LENGTH:	2.690 INCHES MAXIMUM
BODY WIDTH:	2.250 INCHES MAXIMUM
CENTER TO CENTER DISTANCE BETWEEN MOUNTING FACILITIES PARALLEL TO LENGTH:	2.190 INCHES NOMINAL SINGLE MOUNTING FACILITY SINGLE CENTER GROUP
CENTER TO CENTER DISTANCE BETWEEN MOUNTING FACILITIES PARALLEL TO WIDTH:	1.750 INCHES NOMINAL SINGLE MOUNTING FACILITY SINGLE CENTER GROUP
FREQUENCY RATING:	50.0 HERTZ MINIMUM SINGLE COMPONENT AND 400.0 HERTZ MAXIMUM SINGLE COMPONENT
MOUNTING FACILITY QUANTITY:	4 SINGLE GROUP
MOUNTING METHOD:	THREADED HOLE SINGLE GROUP
NOMINAL THREAD SIZE:	0.138 INCHES SINGLE GROUP
INCLOSURE TYPE:	FULLY INCLOSED
INPUT-OUTPUT PHASE RELATIONSHIP:	SINGLE PHASE TO SINGLE PHASE SINGLE COMPONENT
RELIABILITY INDICATOR:	NOT ESTABLISHED
WINDING FUNCTION AND QUANTITY:	2 PRIMARY SINGLE COMPONENT AND 1 SECONDARY SINGLE COMPONENT
WINDING OPERATING CURRENT:	3.0 AMPERES DC MAXIMUM SINGLE COMPONENT SINGLE SECONDARY
WINDING OPERATING VOLTAGE:	115.00 AC VOLTS NOMINAL SINGLE COMPONENT ALL PRIMARY
WINDING OPERATING VOLTAGE:	28.00 DC VOLTS NOMINAL SINGLE COMPONENT SINGLE SECONDARY
TERMINAL TYPE AND QUANTITY:	1 TAB, SOLDER LUG AND 7 WIRE LEAD

Weight and Dimensions

National Stock Number

Box Weight	Box Size	Item Weight	Item Dimensions	FSC	FSG	NIIN	INC
--	--	--	--	5950	59	01-260-6819 / 012606819	32496

National Motor Freight / Schedule B

NMFC	Description	Schedule B
063420	TRANSFORMERS,NOI,OR TRANSFORMER PAR	

BACT42P1-0-2

Terminal Board

DISTANCE FROM LEFT EDGE OF TERMINAL BOARD TO CENTER OF FIRST MOUNTING FACILITY:	0.156 INCHES
END ITEM IDENTIFICATION:	CH-47D,HELICOPTER,CARGO
BOARD CONSTRUCTION:	SCORED FOR EASY BREAKING INTO SMALLER TERMINAL BOARDS
BOARD OVERALL LENGTH:	3.875 INCHES
BOARD OVERALL WIDTH:	1.125 INCHES
BOARD THICKNESS:	0.062 INCHES
BODY STYLE:	STRIP TYPE
CENTER TO CENTER DISTANCE BETWEEN MOUNTING FACILITIES PARALLEL TO LENGTH:	1.625 INCHES
CENTER TO CENTER DISTANCE BETWEEN MOUNTING FACILITIES PARALLEL TO WIDTH:	0.812 INCHES
CENTER TO CENTER DISTANCE BETWEEN TERMINALS:	0.250 INCHES
MATERIAL:	PLASTIC EPOXY BOARD AND GLASS FIBER BOARD
MOUNTING FACILITY TYPE AND QUANTITY:	6 UNTHREADED HOLE
MOUNTING HOLE DIAMETER:	0.144 INCHES
SECTION QUANTITY:	2
TERMINAL FACILITY QUANTITY PER SECTION:	10
TERMINAL FACILITY QUANTITY:	10
TERMINAL PATTERN ARRANGEMENT:	SINGLE ROW

Weight and Dimensions

Box Weight	Box Size	Item Weight	Item Dimensions
.1lbs		--	--

National Motor Freight / Schedule B

NMFC	Description	Schedule B
------	-------------	------------

061045

BOARDS PRINTED
CIRCUIT ELEC

8536908085 / Electrical apparatus for switching or
protecting electrical circuits, or for making connection
to/ in electrical circuits,for a voltage It=1000v,nesoi

National Stock Number

FSC	FSG	NIIN	INC
5940	59	01-264-6267 / 012646267	00404

SC-D-883963G9-3

Electrical Power Cable Assembly

CABLE, CORD, AND WIRE ASSEMBLIES: COMMUNICATION EQUIPMENT NATIONAL STOCK NUMBER 5995-01-134-3159 CABLE ASSEMBLY,POWER,ELECTRICAL.

Weight and Dimensions

National Stock Number

Box Weight	Box Size	Item Weight	Item Dimensions	FSC	FSG	NIIN	INC
127.0lbs	140 X 140 X 140	--	120 X 120 X 120	5995	59	01-134-3159 / 011343159	00485

National Motor Freight / Schedule B

NMFC	Description	Schedule B
030310	CABLE OR WIRE	9030400000 / Other instruments and apparatus, specially designed for telecommunications (for examle, cross-talk meters, gain measuring instruments etc)

305008-1

Ignition Exciter

END ITEM IDENTIFICATION:

F16 AIRCRAFT ENGINE

FSC APPLICATION DATA:

ACFT ENGINE ELECTRICAL SYSTEM COMPONENTS

GENERAL CHARACTERISTICS ITEM DESCRIPTION:

MAX OVERALL LG 5.100 IN.,OVERALL WIDTH 3.180 IN.,MAX H 2.330 IN.

Weight and Dimensions

National Stock Number

Box Weight	Box Size	Item Weight	Item Dimensions	FSC	FSG	NIIN	INC
2.0lbs	--	--	--	2925	29	01-057-6993 / 010576993	77777

National Motor Freight / Schedule B

NMFC	Description	Schedule B
177080	SPARK PLUGS IN BXS	

ADG150

Line Electro-mechanical Actuator

END ITEM IDENTIFICATION:	EI: 6115-01-285-3012, P/N: MEP831A, 3 KW GEN SET
BODY HEIGHT:	3.990 INCHES NOMINAL
BODY LENGTH:	4.400 INCHES NOMINAL
BODY WIDTH:	4.000 INCHES NOMINAL
CURRENT RATING IN AMPS:	0.70 AND 0.90
CURRENT TYPE:	DC
SPECIAL FEATURES:	16 GA WIRE CONNECTION, 6.0 IN LONG W/ CONNECTOR TO MATE W/ 88-20470
TEMP RATING:	-25.0 DEG FAHRENHEIT AND 150.0 DEG FAHRENHEIT
TERMINAL TYPE:	CONNECTOR
VOLTAGE IN VOLTS:	20.0 AND 32.0

Weight and Dimensions

National Stock Number

Box Weight	Box Size	Item Weight	Item Dimensions	FSC	FSG	NIIN	INC
2.0lbs	--	--	--	2920	29	01-477-1320 / 014771320	10957

National Motor Freight / Schedule B

NMFC	Description	Schedule B
177080	SPARK PLUGS IN BXS	8511908000 / Internal combustion engine parts

2915-00-918-8924

Rotating Yoke

ENGINE FUEL SYSTEM COMPONENTS, AIRCRAFT AND MISSILE PRIME MOVERS NATIONAL STOCK NUMBER 2915-00-918-8924 YOKE,ROTATING.

Weight and Dimensions

National Stock Number

Box Weight	Box Size	Item Weight	Item Dimensions	FSC	FSG	NIIN	INC
.1lbs	--	--	--	2915	29	00-918-8924 / 009188924	77777

National Motor Freight / Schedule B

NMFC	Description	Schedule B
051080	FAUCETS,BIBCOCKS,GATES VALVES	

7767321

Adjusting Screw Assembly

GENERAL CHARACTERISTICS ITEM DESCRIPTION:

CONSISTS OF 7403185 SCREW 1,7403186 PAD 1

Weight and Dimensions

National Stock Number

Box Weight	Box Size	Item Weight	Item Dimensions	FSC	FSG	NIIN	INC
.1lbs	--	--	--	2805	28	00-776-7321 / 007767321	7777

National Motor Freight / Schedule B

NMFC	Description	Schedule B
093486	BOLTS,NUTS OR SCREWS, (SUB 3)	

6099-01-528-0712

Furcation Assy

END ITEM IDENTIFICATION: NUCLEAR POWER PLANTS
OVERALL DIAMETER: 22.0 MILLIMETERS MAXIMUM
OVERALL LENGTH: 1915.0 MILLIMETERS MAXIMUM
PART NAME ASSIGNED BY CONTROLLING AGENCY: FURCATION UNITS, TUBE, BLOWN OPTICAL FIBERS
SPECIAL FEATURES: 8EA FURCATION CABLES; 1.8M MIN LENGTH; NON-REMOVEABLE POLYMER TUBING

Weight and Dimensions

National Stock Number

Box Weight	Box Size	Item Weight	Item Dimensions	FSC	FSG	NIIN	INC
.3lbs	--	--	--	6099	60	01-528-0712 / 015280712	77777

0705-8130

Fiber Optic System Repair Kit

END ITEM IDENTIFICATION:

GPETE, (GENERAL PURPOSE ELECTRONIC TEST EQUIPMENT)

PART NAME ASSIGNED BY CONTROLLING AGENCY:

8 CH FURCATION KIT

Weight and Dimensions

National Stock Number

Box Weight	Box Size	Item Weight	Item Dimensions	FSC	FSG	NIIN	INC
--	--	--	--	6080	60	01-525-1216 / 015251216	40976

86015503

Support Upright Shelf

GENERAL CHARACTERISTICS ITEM DESCRIPTION:

MATL 1010 STEEL; O/A LENGTH 72.000 INCHES

National Stock Number

FSC	FSG	NIIN	INC
7110	71	01-319-5111 / 013195111	7777

68d240028-1001

Aircraft Canopy Harness

REFERENCE DATA AND LITERATURE:

TO 1F-15A-4-6

PART NAME ASSIGNED BY CONTROLLING AGENCY:

RESTRAINT,CANPOY SAFETY

SPECIAL FEATURES:

STRAP ASSEMBLY, CANOPY;NYLON;120 LONG, 48 INCH WIDE, 1 INCH THICK

Weight and Dimensions

National Stock Number

Box Weight	Box Size	Item Weight	Item Dimensions	FSC	FSG	NIIN	INC
14.0lbs	205 X 110 X 155	.0lbs	--	1730	17	00-515-0473 / 005150473	05668

National Motor Freight / Schedule B

NMFC	Description	Schedule B
157520	PLATFORMS AIRCRAFT CARGO SHIPNG	8431390090 / Parts for lifting, handling, loading or unloading machinery

3-76070-505

Aircraft Maintenance Sling

SPECIAL FEATURES:

LOAD CAPACITY IS 12,713 LBS

USAGE DESIGN:

AIRCRAFT

Weight and Dimensions

National Stock Number

Box Weight	Box Size	Item Weight	Item Dimensions	FSC	FSG	NIIN	INC
172.0lbs	780 X 215 X 73	.0lbs	--	1730	17	00-477-3426 / 004773426	06403

National Motor Freight / Schedule B

NMFC	Description	Schedule B
157520	PLATFORMS AIRCRAFT CARGO SHIPNG	8431390090 / Parts for lifting, handling, loading or unloading machinery

82A5027A0125

Sling Adapter Quick Disconnect S

END ITEM IDENTIFICATION:

1055011644608

GENERAL CHARACTERISTICS ITEM DESCRIPTION:

MATERIAL SHALL BE UNFORMLY MADE FREE FROM DIRT OIL ETC

Weight and Dimensions

National Stock Number

Box Weight	Box Size	Item Weight	Item Dimensions	FSC	FSG	NIIN	INC
.1lbs	--	--	--	1730	17	01-487-5655 / 014875655	7777

National Motor Freight / Schedule B

NMFC	Description	Schedule B
011790	AIRCRAFT PARTS	

SS04023030-10

Pliers

END ITEM IDENTIFICATION: AMRAAM
FUNCTIONAL DESCRIPTION: USED TO ACCESS THE SAF CONNECTOR W1P2 THROUGH THE CUTOUT IN THE PROPULSION SECTION AND ROTATE IT IN EITHER DIRECTION
INSULATED HANDLE: NOT PROVIDED
SPECIAL FEATURES: SPECIALLY MODIFIED GENERAL PLIERS; ORIGINAL JAWS REMOVED AND REPLACED WITH A PAIR OF ROUND 2.25 IN. LG EXTENDER RODS WELDED TO JAW MOUNTS AT RGHT ANGLES TO THE HANDLES

National Stock Number

FSC	FSG	NIIN	INC
5120	51	01-327-3883 / 013273883	03978

167ATMB

Socket Wrench Set

COMPONENT QUANTITY: 67

FURNISHED ITEMS: METAL BOX

NONSUPPLY ITEMS AND QUANTITIES: CONTAINS 1/4 IN. FEMALE SQ DRIVE SOCKETS IN 6 AND 12 POINT FRACTIONAL SIZES; INCLUDES HANDLES, EXTENSIONS AND VARIOUS SCREWDRIVER ATTACHMENTS

National Stock Number

FSC	FSG	NIIN	INC
5120	51	01-429-3554 / 014293554	17850

CA72-22C

Rivet Bucking Bar

HAND TOOLS, NONEDGED, NONPOWERED NATIONAL STOCK NUMBER 5120-01-023-6453 BAR,BUCKING,RIVET.

National Motor Freight / Schedule B

National Stock Number

NMFC	Description	Schedule B	FSC	FSG	NIIN	INC
186620	TOOLS, HAND OTHER THAN POWER	8205599000 / Handtools (including glass cutters) and parts thereof, of basemetal	5120	51	01-023-6453 / 010236453	06814

T2797-10

Seal Inserter

HAND TOOLS, NONEDGED, NONPOWERED NATIONAL STOCK NUMBER 5120-01-532-7224 INSERTER,SEAL.

National Stock Number

FSC	FSG	NIIN	INC
5120	51	01-532-7224 / 015327224	35963

PWA101620

Plug Removal Wrench

END ITEM IDENTIFICATION: C-17 ACFT

GENERAL CHARACTERISTICS ITEM DESCRIPTION:

USED WITH A 7/8 IN. OPEN WRENCH,NOT INCL,TO REMOVE BORESCOPE PLUG; CONSISTS OF A MACHINED WRENCH ASSY TO WHICH A SOCKET HAS BEEN WELDED,A THREADED ROD PASSES THRU THE WRENCH ASSY AND IS ACTUATED USING A KNURLED KNOB; IS 16.0 IN. BY 1.2 IN. DIA,MATL STEEL,FINISH BLACK OXIDE

Weight and Dimensions

National Stock Number

Box Weight	Box Size	Item Weight	Item Dimensions	FSC	FSG	NIIN	INC
--	--	.0lbs	--	5120	51	01-244-1873 / 012441873	77777

850246

Torque Wrench

DRIVE SURFACE SIZE: 0.375 INCHES NOMINAL SINGLE END
 DRIVE END SHAPE: SQUARE SINGLE END EXTERNAL
 MATERIAL: STEEL OVERALL
 OVERALL LENGTH: 13.500 INCHES NOMINAL
 SPECIAL FEATURES: PIVOTED HANDLE
 SURFACE TREATMENT: CHROMIUM OVERALL
 TORQUE INDICATING MECHANISM: PLATE
 TORQUE CAPACITY: 0.0 INCH-POUNDS MINIMUM AND 600.0 INCH-POUNDS MAXIMUM
 TORQUE SCALE GRADUATION: 25.00 INCH-POUNDS
 TORQUE SIGNAL METHOD: AUDIBLE AND FEEL IMPULSE

National Motor Freight / Schedule B

National Stock Number

NMFC	Description	Schedule B	FSC	FSG	NIIN	INC
186620	TOOLS, HAND OTHER THAN POWER	8204110060 / Hand-operated spanners and wrenches, nonadjustable, and parts, base metal, other	5120	51	00-720-0714 / 007200714	17611

5140-01-613-4336

Tool Bag

OVERALL HEIGHT: 9.0 INCHES NOMINAL
OVERALL LENGTH: 19.0 INCHES NOMINAL
OVERALL WIDTH: 6.0 INCHES NOMINAL
PART NAME ASSIGNED BY CONTROLLING AGENCY: KIT, TOOLS, BAG CNVS, OLIVE

National Stock Number

FSC	FSG	NIIN	INC
5140	51	01-613-4336 / 016134336	52950

169341-1

Hand Terminal Crimping Tool

FEATURES PROVIDED:

OPERATION METHOD:

WIRE SIZE ACCOMMODATED:

CUTTING JAW

MANUAL COMPRESSION

0.0079 AWG MINIMUM AND 0.0319 AWG MAXIMUM

National Stock Number

FSC	FSG	NIIN	INC
5120	51	01-230-4005 / 012304005	06997

806602-01

Spanner Wrench

III PART NAME ASSIGNED BY CONTROLLING AGENCY:

SPANNER WRENCH

National Stock Number

FSC	FSG	NIIN	INC
5120	51	01-631-9214 / 016319214	03476

TO2298

Valve Tappet Adjusting Tool

PART NAME ASSIGNED BY CONTROLLING AGENCY:

TOOL-RELIEF VALVE

National Stock Number

FSC	FSG	NIIN	INC
5120	51	01-591-2120 / 015912120	13618

1222287

Piece Locating

GENERAL CHARACTERISTICS ITEM DESCRIPTION:

IS MADE OF COML PLASTIC,POLYAMIDE NYLON,RIGID;5 HOLES ARE 100 DEGREES BY .132 DEGREES DEEP

National Stock Number

FSC	FSG	NIIN	INC
5120	51	01-487-7076 / 014877076	77777

J-22342-D

Injector Tube Reconditioning Set

END ITEM IDENTIFICATION:

DETROIT DIESEL SERIES 149 ENGINES

National Motor Freight / Schedule B

National Stock Number

NMFC	Description	Schedule B	FSC	FSG	NIIN	INC
186620	TOOLS, HAND OTHER THAN POWER		5120	51	01-130-8867 / 011308867	77777

5140-00-319-5079

Portable Tool Box

DRAWER QUANTITY: 7
 CLOSING FACILITY TYPE AND QUANTITY: LUGGAGE CATCH2
 COMPARTMENT QUANTITY PER DRAWER: 2
 COMPARTMENTED DRAWER QUANTITY: 6
 COMPARTMENT: INCLUDED
 COLOR: RED
 HANDLE LOCATION: TOP
 HANDLE QUANTITY: 1
 MATERIAL: STEEL
 OVERALL HEIGHT: 13.000 INCHES MINIMUM AND 14.250 INCHES MAXIMUM
 LOCK TYPE: KEY
 LOCKING DEVICE TYPE: INTEGRAL
 OVERALL LENGTH: 20.000 INCHES MINIMUM AND 20.750 INCHES MAXIMUM
 OVERALL WIDTH: 8.500 INCHES MINIMUM AND 9.125 INCHES MAXIMUM
 PANEL FRONT: PROVIDED
 SURFACE TREATMENT: ENAMEL
 TOP TILL: PROVIDED

National Motor Freight / Schedule B

National Stock Number

NMFC	Description	Schedule B	FSC	FSG	NIIN	INC
029790	BOXES R CHESTS TOOL/FISH TACKLE	4819600000 / Box files, letter trays, storage boxes and similar articles, of a kind used in offices, shops or the like	5140	51	00-319-5079 / 003195079	22043

Z5MT-3

Screwdriver Bit

DRIVE SHANK TYPE:	HEXAGON
FEATURES PROVIDED:	POWER DRIVEN TOOL PROVISION
OVERALL LENGTH:	1.250 INCHES NOMINAL
SHANK WIDTH ACROSS WRENCH FLATS:	0.313 INCHES NOMINAL
TIP SIZE DESIGNATION:	3
TIP TYPE:	PHILLIPS CROSS

National Stock Number

FSC	FSG	NIIN	INC
5130	51	01-586-1893 / 015861893	03503

5140-01-613-4336

Tool Bag

OVERALL HEIGHT: 9.0 INCHES NOMINAL
OVERALL LENGTH: 19.0 INCHES NOMINAL
OVERALL WIDTH: 6.0 INCHES NOMINAL
PART NAME ASSIGNED BY CONTROLLING AGENCY: KIT, TOOLS, BAG CNVS, OLIVE

National Stock Number

FSC	FSG	NIIN	INC
5140	51	01-613-4336 / 016134336	52950

377054-2

Butt Hinge Leaf

HINGE PIN:	NOT INCLUDED
MATERIAL THICKNESS:	0.050 INCHES NOMINAL
KNUCKLE LENGTH:	0.600 INCHES MINIMUM AND 0.610 INCHES MAXIMUM
KNUCKLE QUANTITY:	23
KNUCKLE TYPE:	FRICTION
MATERIAL AND LOCATION:	ALUMINUM ALLOY OVERALL
REVERSIBLE FEATURE:	NOT INCLUDED
OVERALL LENGTH:	35.300 INCHES NOMINAL
PERFORMANCE TYPE:	LIGHT DUTY
PIN CENTER TO BODY EDGE DISTANCE:	0.810 INCHES NOMINAL
STYLE DESIGNATOR:	BUTT BLANK
SURFACE TREATMENT AND LOCATION:	ANODIZED OVERALL

Weight and Dimensions

National Stock Number

Box Weight	Box Size	Item Weight	Item Dimensions	FSC	FSG	NIIN	INC
.4lbs	--	--	--	5340	53	00-808-7272 / 008087272	07655

National Motor Freight / Schedule B

NMFC	Description	Schedule B
095290	HINGES/BUTTS METAL O/T I/S	

205-031-515-2

Rim Latch

HARDWARE, COMMERCIAL NATIONAL STOCK NUMBER 5340-01-483-1353 LATCH,RIM.

National Stock Number

FSC	FSG	NIIN	INC
5340	53	01-483-1353 / 014831353	06623

94700-3F7

Socket Head Cap Screw

END ITEM IDENTIFICATION:	5855-01-464-3150
COUNTERSINK ANGLE:	80.0 DEGREES MINIMUM AND 82.0 DEGREES MAXIMUM
FASTENER LENGTH:	0.437 INCHES NOMINAL
HEAD DIAMETER:	0.359 INCHES MINIMUM AND 0.411 INCHES MAXIMUM
HEAD STYLE:	FLAT COUNTERSUNK
MATERIAL:	STEEL OVERALL
NOMINAL THREAD DIAMETER:	0.190 INCHES
INTERNAL DRIVE STYLE:	HEXAGON
WIDTH ACROSS FLATS:	0.125 INCHES NOMINAL
SURFACE TREATMENT:	OXIDE OVERALL AND OIL OVERALL
THREAD CLASS:	3A
THREAD DIRECTION:	RIGHT-HAND
THREAD LENGTH:	0.310 INCHES NOMINAL
THREAD QUANTITY PER INCH:	32
THREAD SERIES DESIGNATOR:	UNF

Weight and Dimensions

National Stock Number

Box Weight	Box Size	Item Weight	Item Dimensions	FSC	FSG	NIIN	INC
--	250 X 50 X 40	--	--	5305	53	01-504-3389 / 015043389	16282

National Motor Freight / Schedule B

NMFC	Description	Schedule B
096640	SCREWS, IRON OR STEEL	7318152000 / Bolts and bolts and their nuts or washers exported in the same shipment

080-04273-107

O-ring

CENTER HOLE DIAMETER: 0.177 INCHES MINIMUM AND 0.187 INCHES MAXIMUM
CROSS-SECTIONAL HEIGHT: 0.032 INCHES MINIMUM AND 0.038 INCHES MAXIMUM
MATERIAL: RUBBER BUTADIENE-ACRYLONITRILE CLASS NBR

Weight and Dimensions

National Stock Number

Box Weight	Box Size	Item Weight	Item Dimensions	FSC	FSG	NIIN	INC
.1lbs	--	--	--	5331	53	00-777-2595 / 007772595	47946

National Motor Freight / Schedule B

NMFC	Description	Schedule B
194120	WASHERS/GASKETS/PCKG DVCS	4016930000 / Gaskets, washers and other seals, of vulcanized rubber other than hard rubber

8671112

Compression Helical Spring

COIL HELIX DIRECTION: RIGHT-HAND OR LEFT-HAND
COIL QUANTITY: 8
END STYLE: SPRING END,SQUARED AND GROUND BOTH ENDS
MATERIAL: STEEL COMP 5160H OVERALL OR STEEL COMP 8655H OVERALL OR STEEL COMP 8660 OVERALL OR STEEL COMP 9262 OVERALL
INSIDE DIAMETER: 11.750 INCHES MINIMUM AND 11.820 INCHES MAXIMUM
SPRING DEFLECTION RATE: 130.000 POUNDS PER INCH NOMINAL
SPRING FREE LENGTH: 45.000 INCHES NOMINAL
SPRING FREE OUTSIDE DIAMETER: 13.620 INCHES NOMINAL
SPRING SOLID LENGTH: 9.000 INCHES NOMINAL
SPRING SOLID OUTSIDE DIAMETER: 14.120 INCHES NOMINAL
STYLE DESIGNATOR: CYLINDRICAL
SURFACE TREATMENT: PHOSPHATE MANGANESE OVERALL

Weight and Dimensions

National Stock Number

Box Weight	Box Size	Item Weight	Item Dimensions	FSC	FSG	NIIN	INC
--	--	--	--	5360	53	00-089-2699 / 000892699	04226

National Motor Freight / Schedule B

NMFC	Description	Schedule B
177970	SPRINGS STL O/T WIRE	

8754216

Weapon System Resilient Mount

HEIGHT:	1.480 INCHES NOMINAL
MATERIAL:	STEEL OVERALL
MINOR OUTSIDE DIAMETER:	2.000 INCHES NOMINAL
INSIDE DIAMETER:	0.600 INCHES NOMINAL
MAJOR OUTSIDE DIAMETER:	2.625 INCHES NOMINAL
UNABLE TO DECODE:	UNABLE TO DECODE

Weight and Dimensions

National Stock Number

Box Weight	Box Size	Item Weight	Item Dimensions	FSC	FSG	NIIN	INC
3.0lbs	--	--	--	5342	53	00-678-3304 / 006783304	53589

National Motor Freight / Schedule B

NMFC	Description	Schedule B
093600	BRACKETS/BUSHINGS/JOINTS/MOUNTS ETC	8710000090 / Parts of armored fighting vehicles,motorized, whether or not fitted with weapons

9177346-9

Plain Seal

PACKING AND GASKET MATERIALS NATIONAL STOCK NUMBER 5330-00-200-0221 SEAL,PLAIN.

Weight and Dimensions

National Stock Number

Box Weight	Box Size	Item Weight	Item Dimensions	FSC	FSG	NIIN	INC
.1lbs	--	--	--	5330	53	00-200-0221 / 002000221	04250

National Motor Freight / Schedule B

NMFC	Description	Schedule B
194120	WASHERS/GASKETS/PCKG DVCS	3926904500 / Gaskets,washers & other seals

341207-5

Mounting Bracket

HARDWARE, COMMERCIAL NATIONAL STOCK NUMBER 5340-01-337-9551 BRACKET,MOUNTING.

Weight and Dimensions

National Stock Number

Box Weight	Box Size	Item Weight	Item Dimensions	FSC	FSG	NIIN	INC
.6lbs	--	--	--	5340	53	01-337-9551 / 013379551	38089

National Motor Freight / Schedule B

NMFC	Description	Schedule B
095190	HARDWARE,	

3329847-1

Clampblock Assembly

END ITEM IDENTIFICATION:

HF FLUSH ANTENNA LEAD, HERCULES C130J FIXED WING ACFT

OVERALL DIAMETER:

2.000 INCHES NOMINAL

National Stock Number

FSC	FSG	NIIN	INC
5340	53	01-441-3964 / 014413964	7777

MS17984C818

Quick Release Pin

END ITEM IDENTIFICATION:	ENGINE, AIRCRAFT, F110-GE-100;VIRGINIA CLASS CGN (41);OLIVER PERRY CLASS FFG;LAV, ANTI-TANK;GENERAL HANDLING EQUIPMENT;RH-53 HELICOPTER;F/A-18 HORNET;HARRIER
ACTUATION METHOD:	PUSH BUTTON
ACTUATION TYPE:	PUSH
BUTTON HANDLE DIAMETER:	1.300 INCHES MINIMUM AND 1.400 INCHES MAXIMUM
DETENT QUANTITY:	2
DETENT TO TAPERED END DISTANCE:	0.460 INCHES MAXIMUM
GRIP LENGTH:	1.800 INCHES MINIMUM AND 1.820 INCHES MAXIMUM
HARDNESS RATING:	40.0 ROCKWELL C MINIMUM SHANK
HARDNESS RATING:	40.0 ROCKWELL C MINIMUM SPINDLE
MATERIAL:	STEEL COMP 630 SHANK OR STEEL COMP 632 SHANK
MATERIAL:	STEEL COMP 630 SPINDLE OR STEEL COMP 632 SPINDLE
MATERIAL DOCUMENT AND CLASSIFICATION:	AMS 5643 ASSN STD 1ST MATERIAL RESPONSE SHANK OR AMS 5657 ASSN STD 2ND MATERIAL RESPONSE SHANK
MATERIAL DOCUMENT AND CLASSIFICATION:	AMS 5643 ASSN STD 1ST MATERIAL RESPONSE SPINDLE OR AMS 5657 ASSN STD 2ND MATERIAL RESPONSE SPINDLE
SHANK DIAMETER:	0.4970 INCHES MINIMUM AND 0.4985 INCHES MAXIMUM
SHEAR STRENGTH:	36800 DOUBLE POUND
SHOULDER TO HEAD END DISTANCE:	1.190 INCHES MAXIMUM
PIN ATTACHMENT TYPE:	HOOK OR RING

Weight and Dimensions

National Stock Number

Box Weight	Box Size	Item Weight	Item Dimensions	FSC	FSG	NIIN	INC
.2lbs	--	--	--	5315	53	00-252-9921 / 002529921	08323

National Motor Freight / Schedule B

NMFC	Description	Schedule B
095190	HARDWARE, SUB 9	

5325-00-045-7365

Retaining Ring

CASEHARDENING INDICATOR: NOT CASEHARDENED
CROSS-SECTIONAL SHAPE STYLE: RECTANGULAR
MATERIAL: IRON
OUTSIDE DIAMETER: 7.000 INCHES NOMINAL
INSIDE DIAMETER: 6.458 INCHES MINIMUM AND 6.488 INCHES MAXIMUM
MAJOR THICKNESS: 0.153 INCHES MINIMUM AND 0.155 INCHES MAXIMUM
RING STYLE: SPLIT
USAGE DESIGN: EXTERNAL

Weight and Dimensions

National Stock Number

Box Weight	Box Size	Item Weight	Item Dimensions	FSC	FSG	NIIN	INC
.4lbs		--	--	5325	53	00-045-7365 / 000457365	07623

National Motor Freight / Schedule B

NMFC	Description	Schedule B
095190	HARDWARE,	9606100000 / Press-fasteners, snap-fasteners & press-studs & parts therefor

4010222

Clinch Self-locking Nut

MATERIAL: IRON ALLOY 660 OVERALL
NOMINAL THREAD SIZE: 0.190 INCHES
LOCKING FEATURE: PREVAILING TORQUE ALL METAL DESIGN
MATERIAL DOCUMENT AND CLASSIFICATION: AMS 5735 ASSN STD SINGLE MATERIAL RESPONSE OVERALL OR AMS 5737 ASSN STD SINGLE MATERIAL RESPONSE OVERALL
THREAD CLASS: 3B
THREAD DIRECTION: RIGHT-HAND
THREAD QUANTITY PER INCH: 32
THREAD SERIES: UNJF

Weight and Dimensions

National Stock Number

Box Weight	Box Size	Item Weight	Item Dimensions	FSC	FSG	NIIN	INC
.1lbs	--	--	--	5310	53	00-365-2912 / 003652912	15892

National Motor Freight / Schedule B

NMFC	Description	Schedule B
013540	ALUM NUTS	7318160000 / Nuts of iron or steel

12312140-5

Quick Release Pin

END ITEM IDENTIFICATION:

M1 TANK

Weight and Dimensions

National Stock Number

Box Weight	Box Size	Item Weight	Item Dimensions	FSC	FSG	NIIN	INC
.2lbs	--	--	--	5315	53	01-145-5189 / 011455189	08323

National Motor Freight / Schedule B

NMFC	Description	Schedule B
095190	HARDWARE,	

9M366H5-7200

Butt Hinge Leaf

HINGE PIN:	NOT INCLUDED
HINGE MOUNTING TYPE:	FULL SURFACE
MATERIAL THICKNESS:	0.044 INCHES MINIMUM AND 0.056 INCHES MAXIMUM
KNUCKLE INSIDE DIAMETER:	0.094 INCHES MINIMUM AND 0.099 INCHES MAXIMUM
KNUCKLE LENGTH:	0.491 INCHES MINIMUM AND 0.495 INCHES MAXIMUM
KNUCKLE QUANTITY:	72
KNUCKLE TYPE:	FRICTION
MATERIAL AND LOCATION:	ALUMINUM ALLOY, QQ-A-200/3, ALLOY 2024, T8511 OVERALL
REVERSIBLE FEATURE:	NOT INCLUDED
OVERALL LENGTH:	71.980 INCHES MINIMUM AND 72.020 INCHES MAXIMUM
PERFORMANCE TYPE:	NOT RATED
PIN CENTER TO BODY EDGE DISTANCE:	0.875 INCHES NOMINAL
STYLE DESIGNATOR:	BUTT BLANK
SURFACE TREATMENT AND LOCATION:	DICHROMATE, P.S.13201, TYPE 2, MCDONNELL DOUGLAS CORP OVERALL

Weight and Dimensions

National Stock Number

Box Weight	Box Size	Item Weight	Item Dimensions	FSC	FSG	NIIN	INC
1.0lbs	--	--	--	5340	53	01-232-9962 / 012329962	07655

National Motor Freight / Schedule B

NMFC	Description	Schedule B
095300	HINGES/BUTTS I/S	

MIL-H-15021 TY 1

Snap Hook

END CONNECTION STYLE:	SWIVEL
CONNECTION END MATERIAL:	BRASS
DESIGN TYPE:	SWIVEL
HOOK MATERIAL:	BRASS
HOOK STYLE DESIGNATOR:	SLIDING BOLT
INSIDE WIDTH:	0.750 INCHES NOMINAL
RUBBER COVERED FEATURE:	NOT INCLUDED
OVERALL LENGTH:	3.500 INCHES NOMINAL
UNATTACHED RING:	INCLUDED

Weight and Dimensions

National Stock Number

Box Weight	Box Size	Item Weight	Item Dimensions	FSC	FSG	NIIN	INC
.2lbs	--	--	--	5340	53	00-275-4584 / 002754584	16954

National Motor Freight / Schedule B

NMFC	Description	Schedule B
095370	HOOKS I/S GALVANIZE/PLAIN ETC	

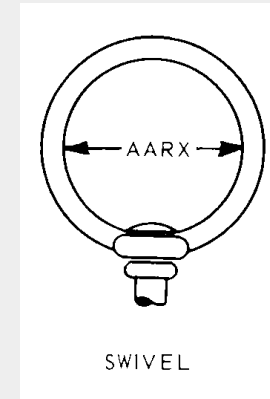

5342-00-679-7612

Dashpot

GENERAL CHARACTERISTICS ITEM DESCRIPTION: COMPOSED OF CYLINDER 2,ELBOW 1,FELT 1,GASKET 1,HEAD 1,NUT 1,PACKING 5,PIN 2,PISTON 1,PLUG 1,RETAINER 2,RING 4,ROD 1,SCRAPER 1,SCREW 10,SLEEVE 1,SPACER 2,SPRING 4,STOP 1,WASHER 10

National Motor Freight / Schedule B

National Stock Number

NMFC	Description	Schedule B	FSC	FSG	NIIN	INC
129940	SHOCK ABSORBERS/PARTS RUBR/STL	8487900080 / Machinery parts not containing electrical features, and not specified or included elsewhere in chapter 84, except ships' propellers	5342	53	00-679-7612 / 006797612	24460

LS5949-1

Dust And Moistu Protective Cover

END ITEM IDENTIFICATION:

HERCULES C-130 AIRCRAFT

National Stock Number

FSC	FSG	NIIN	INC
5340	53	01-437-0900 / 014370900	49602

11460539-4

Rim Latch

HARDWARE, COMMERCIAL NATIONAL STOCK NUMBER 5340-01-254-1600 LATCH,RIM.

Weight and Dimensions

National Stock Number

Box Weight	Box Size	Item Weight	Item Dimensions	FSC	FSG	NIIN	INC
1.4lbs	--	--	--	5340	53	01-254-1600 / 012541600	06623

National Motor Freight / Schedule B

NMFC	Description	Schedule B
095190	HARDWARE, SUB 9	

5340-00-543-3173

Webbing Strap

END ATTACHMENT/FASTENING FACILITY:	BUCKLE
END ATTACHMENT/FASTENING FACILITY:	END CLIP
END CLIP MATERIAL:	BRASS
END CLIP QUANTITY:	1
END CLIP STYLE DESIGNATOR:	BALL CLIP
ATTACHMENT METHOD FOR WHICH DESIGNED:	SEWED
BUCKLE FASTENING METHOD:	SEWED
BUCKLE LOCATION:	ON END
BUCKLE MATERIAL:	STEEL
BUCKLE STYLE DESIGNATOR:	NOTCHED EDGE
BUCKLE SURFACE TREATMENT:	PHOSPHATE
COLOR:	OLIVE DRAB
END TYPE:	FOLDED
ENVIRONMENTAL PROTECTION:	MILDEW RESISTANT AND WATER RESISTANT
FASTENED BUCKLE FEATURE:	INCLUDED
FOLD TYPE:	LOOSE
MATERIAL:	PLASTIC POLYHEXAMETHYLENE ADIPAMIDE

Weight and Dimensions

National Stock Number

Box Weight	Box Size	Item Weight	Item Dimensions	FSC	FSG	NIIN	INC
.2lbs	--	--	--	5340	53	00-543-3173 / 005433173	20659

National Motor Freight / Schedule B

NMFC	Description	Schedule B
179580	STRAPS LEATHER IMITATION LEATHER	

11460539-3

Rim Latch

HARDWARE, COMMERCIAL NATIONAL STOCK NUMBER 5340-01-254-1601 LATCH,RIM.

Weight and Dimensions

National Stock Number

Box Weight	Box Size	Item Weight	Item Dimensions	FSC	FSG	NIIN	INC
1.2lbs	--	--	--	5340	53	01-254-1601 / 012541601	06623

National Motor Freight / Schedule B

NMFC	Description	Schedule B
095190	HARDWARE, SUB 9	

803-2145600-8 TY B

Weapon System Resilient Mount

DISTANCE FROM FLANGE TO END:	0.813 INCHES NOMINAL
FLANGE THICKNESS:	0.188 INCHES NOMINAL
HEIGHT:	1.188 INCHES NOMINAL
MATERIAL:	STEEL WASHER
MATERIAL:	STEEL INNER BUSHING
INSIDE DIAMETER:	0.313 INCHES NOMINAL
MATERIAL DOCUMENT AND CLASSIFICATION:	MIL-S-20166 MIL SPEC SINGLE MATERIAL RESPONSE INNER BUSHING OR MIL-S-22698 MIL SPEC SINGLE MATERIAL RESPONSE INNER BUSHING OR MIL-S-24113 MIL SPEC SINGLE MATERIAL RESPONSE INNER BUSHING OR ASTM A36 ASSN STD SINGLE MATERIAL RESPONSE INNER BUSHING OR ASTM A537 ASSN STD SINGLE MATERIAL RESPONSE INNER BUSHING OR ASTM A515, GRADE 70 ASSN STD SINGLE MATERIAL RESPONSE INNER BUSHING OR ASTM A516, GRADE 70 ASSN STD SINGLE MATERIAL RESPONSE INNER BUSHING OR ASTM A675, GRADE 70 ASSN STD SINGLE MATERIAL RESPONSE INNER BUSHING
MATERIAL DOCUMENT AND CLASSIFICATION:	MIL-S-20166 MIL SPEC SINGLE MATERIAL RESPONSE WASHER OR MIL-S-22698 MIL SPEC SINGLE MATERIAL RESPONSE WASHER OR MIL-S-24113 MIL SPEC SINGLE MATERIAL RESPONSE WASHER OR ASTM A36 ASSN STD SINGLE MATERIAL RESPONSE WASHER OR ASTM A537 ASSN STD SINGLE MATERIAL RESPONSE WASHER OR ASTM A515, GRADE 70 ASSN STD SINGLE MATERIAL RESPONSE WASHER OR ASTM A516, GRADE 70 ASSN STD SINGLE MATERIAL RESPONSE WASHER OR ASTM A675, GRADE 70 ASSN STD SINGLE MATERIAL RESPONSE WASHER
SURFACE TREATMENT DOCUMENT AND CLASSIFICATION:	MIL-P-23236, TYPE 1, CLASS 1 MIL SPEC SINGLE TREATMENT RESPONSE INNER BUSHING
SURFACE TREATMENT DOCUMENT AND CLASSIFICATION:	MIL-P-23236, TYPE 1, CLASS 1 OR 2 MIL SPEC SINGLE TREATMENT RESPONSE OVERALL
SURFACE TREATMENT:	PAINT INNER BUSHING
SURFACE TREATMENT:	PAINT OVERALL
UNABLE TO DECODE:	UNABLE TO DECODE AND UNABLE TO DECODE
UNABLE TO DECODE:	UNABLE TO DECODE

Weight and Dimensions

Box Weight	Box Size	Item Weight	Item Dimensions	FSC	FSG	NIIN	INC
.1lbs	--	--	--	5342	53	01-137-3293 / 011373293	53589

National Stock Number

National Motor Freight / Schedule B

NMFC	Description	Schedule B
093600	BRACKETS/BUSHINGS/JOINTS/MOUNTS ETC	8710000090 / Parts of armored fighting vehicles,motorized, whether or not fitted with weapons

2611827

Plain Encased Seal

END ITEM IDENTIFICATION:

PREPROVISIONING SUPPORT NAVICP IS POE

Weight and Dimensions

National Stock Number

Box Weight	Box Size	Item Weight	Item Dimensions	FSC	FSG	NIIN	INC
--		--	--	5330	53	01-455-1427 / 014551427	04214

National Motor Freight / Schedule B

NMFC	Description	Schedule B
194120	WASHERS/GASKETS/PCKG DVCS	8484200000 / Mechanical seals

7416866

Mounting Bracket

END ITEM IDENTIFICATION:

2350-00-439-6242 RECOVERY VEH FT

SPECIAL FEATURES:

CONSISTS OF:1 EA. YOKE,P/N 8739555;1 EA. STUD,P/N 8739554;1 EA. PIN,MS35674-18

Weight and Dimensions

National Stock Number

Box Weight	Box Size	Item Weight	Item Dimensions	FSC	FSG	NIIN	INC
2.2lbs	96 X 82 X 16	--	--	5340	53	01-008-6448 / 010086448	38089

National Motor Freight / Schedule B

NMFC	Description	Schedule B
095190	HARDWARE, SUB 9	

400216

Door Closer

CONTROL TYPE: AIR
MATERIAL: STEEL CORROSION RESISTING ARM
MATERIAL: STEEL CORROSION RESISTING CASE
MOUNTING TYPE FOR WHICH DESIGNED: SURFACE
LENGTH: 10.330 INCHES NOMINAL OVERALL
SPECIAL FEATURES: PRESS TO RELEASE MECHANISM IN ROD OR USE RELEASE RING AT END OF ROD;HOLDING ANGLE IN DEGS:90;TUBE DIA:0.875 IN. DIA
SURFACE TREATMENT: PASSIVATE OVERALL
UNIT TYPE: DOUBLE ACTION

Weight and Dimensions

National Stock Number

Box Weight	Box Size	Item Weight	Item Dimensions	FSC	FSG	NIIN	INC
.7lbs	--	--	--	5340	53	00-014-9479 / 000149479	06689

National Motor Freight / Schedule B

NMFC	Description	Schedule B
094500	DOOR CHECKS AUTOMATIC METAL	

135B6695

Headless Straight Pin

FIRST END STYLE:	CHAMFERED
FIRST END TAPER ANGLE:	9.0 DEGREES MINIMUM AND 11.0 DEGREES MAXIMUM
FIRST END TAPER LENGTH:	0.050 INCHES MINIMUM AND 0.070 INCHES MAXIMUM
MATERIAL:	STEEL OVERALL
MATERIAL DOCUMENT AND CLASSIFICATION:	ASTM A108 ASSN STD SINGLE MATERIAL RESPONSE OVERALL
SECOND END RELATIONSHIP WITH FIRST END:	IDENTICAL
PIN OVERALL DIAMETER:	0.1098 INCHES MINIMUM AND 0.1100 INCHES MAXIMUM
PIN OVERALL LENGTH:	1.300 INCHES MINIMUM AND 1.390 INCHES MAXIMUM
SURFACE FINISH:	32.0 MICROINCHES OUTSIDE DIAMETER

Weight and Dimensions

National Stock Number

Box Weight	Box Size	Item Weight	Item Dimensions	FSC	FSG	NIIN	INC
.1lbs	--	--	--	5315	53	00-349-8115 / 003498115	02390

National Motor Freight / Schedule B

NMFC	Description	Schedule B
095190	HARDWARE, SUB 9	7319409000 / Pins of iron or steel nesoi

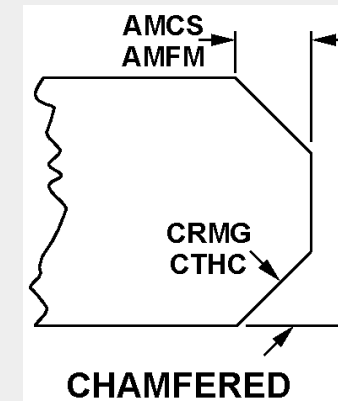

330 0234

Preformed Packing

END ITEM IDENTIFICATION:

2320011231608

Weight and Dimensions

National Stock Number

Box Weight	Box Size	Item Weight	Item Dimensions	FSC	FSG	NIIN	INC
.2lbs	--	--	--	5330	53	01-223-4039 / 012234039	04521

National Motor Freight / Schedule B

NMFC	Description	Schedule B
194120	WASHERS/GASKETS/PCKG DVCS	3926904500 / Gaskets,washers & other seals

62416-421-1

Gasket

PACKING AND GASKET MATERIALS NATIONAL STOCK NUMBER 5330-01-622-6537 GASKET.

National Motor Freight / Schedule B

National Stock Number

NMFC	Description	Schedule B	FSC	FSG	NIIN	INC
194120	WASHERS/GASKETS/PCKG DVCS		5330	53	01-622-6537 / 016226537	04522

5331-00-412-9908

O-ring

CENTER HOLE DIAMETER: 7.583 INCHES MINIMUM AND 7.643 INCHES MAXIMUM
CROSS-SECTIONAL HEIGHT: 0.067 INCHES MINIMUM AND 0.073 INCHES MAXIMUM
MATERIAL: RUBBER BUTADIENE-ACRYLONITRILE CLASS NBR

Weight and Dimensions

National Stock Number

Box Weight	Box Size	Item Weight	Item Dimensions	FSC	FSG	NIIN	INC
.1lbs	--	--	--	5331	53	00-412-9908 / 004129908	47946

National Motor Freight / Schedule B

NMFC	Description	Schedule B
194120	WASHERS/GASKETS/PCKG DVCS	4016930000 / Gaskets, washers and other seals, of vulcanized rubber other than hard rubber

342129-10

Headed Straight Pin

CHAMFER LENGTH: 0.100 INCHES NOMINAL
DIAMETER: 0.080 INCHES NOMINAL
HEAD LENGTH: 0.450 INCHES NOMINAL
HEAD RADIUS: 0.180 INCHES NOMINAL
HEAD STYLE: L SHAPE
MATERIAL: TITANIUM ALLOY UNS R56401 OVERALL
PIN HEAD DIAMETER: 0.080 INCHES NOMINAL
STYLE DESIGNATOR: STRAIGHT
UNDER HEAD LENGTH: 25.750 INCHES NOMINAL

National Stock Number

FSC	FSG	NIIN	INC
5315	53	01-412-4988 / 014124988	02384

5330-00-222-2592

Packing Material

CROSS SECTION OUTSIDE DIAMETER: 0.250 INCHES NOMINAL
CROSS-SECTIONAL SHAPE STYLE: CIRCULAR
FABRICATION METHOD: SOLID
MATERIAL: RUBBER SYNTHETIC
MINIMUM TENSILE STRENGTH: 1000 POUNDS PER SQUARE INCH
LENGTH: 1200.000 INCHES NOMINAL
TEMP RATING: -20.0 DEG FAHRENHEIT

Weight and Dimensions

National Stock Number

Box Weight	Box Size	Item Weight	Item Dimensions	FSC	FSG	NIIN	INC
.1lbs	--	--	--	5330	53	00-222-2592 / 002222592	04531

National Motor Freight / Schedule B

NMFC	Description	Schedule B
148520	PACKING RUBR/GUM COMPOUND O/T FOAM	

2047534-1

Dust And Moisture Seal Boot

BASE INSIDE DIAMETER:	0.980 INCHES MINIMUM AND 1.000 INCHES MAXIMUM
FSC APPLICATION DATA:	DRIVE,MECHANICAL,FLAP,LEADING EDGE,WING
MATERIAL:	RUBBER BODY
MOUNTING METHOD:	FRICTION
OPENING INSIDE DIAMETER:	0.490 INCHES MINIMUM AND 0.500 INCHES MAXIMUM
OVERALL HEIGHT:	1.630 INCHES MINIMUM AND 1.650 INCHES MAXIMUM
MATERIAL DOCUMENT AND CLASSIFICATION:	MIL-R-25988,TYPE 2,CLASS 2,GRADE 50 MIL SPEC SINGLE MATERIAL RESPONSE BODY
STYLE DESIGNATOR:	THRU-HOLE

Weight and Dimensions

National Stock Number

Box Weight	Box Size	Item Weight	Item Dimensions	FSC	FSG	NIIN	INC
.1lbs	--	--	--	5340	53	01-146-8164 / 011468164	19302

National Motor Freight / Schedule B

NMFC	Description	Schedule B
133300	MACHINERY/MACHINES	

AS21919WDG64

Loop Clamp

DISTANCE FROM LOOP CENTER TO TONGUE END:	2.467 NOMINAL INCHES
CENTER TO CENTER DISTANCE BETWEEN LOOP AND MOUNTING HOLE:	2.500 INCHES NOMINAL
CUSHIONING ENVIRONMENTAL PROTECTION:	WEATHER RESISTANT
DIAMETER:	0.218 INCHES MINIMUM AND 0.228 INCHES MAXIMUM
MATERIAL THICKNESS:	0.062 NOMINAL INCHES
MATERIAL:	ALUMINUM ALLOY 2024 BAND
MATERIAL:	RUBBER CHLOROPRENE CLASS CR CUSHION
LOOP INSIDE DIAMETER:	4.000 INCHES NOMINAL
MATERIAL DIAMETER:	0.062 NOMINAL INCHES
OVERALL WIDTH:	4.000 INCHES NOMINAL
SPECIFICATION/STANDARD DATA:	96906-MS21919 GOVERNMENT STANDARD AND 96906-AS21919WDG GOVERNMENT SPECIFICATION AND 81349-MIL-C-8603 GOVERNMENT SPECIFICATION
STYLE DESIGNATOR:	SINGLE LOOP
TONGUE HOLE TYPE:	ROUND, UNTHREADED

National Motor Freight / Schedule B

National Stock Number

NMFC	Description	Schedule B	FSC	FSG	NIIN	INC
095190	HARDWARE,		5340	53	01-590-9522 / 015909522	17532

7271GX

Plain Stud

STUDS NATIONAL STOCK NUMBER 5307-01-236-5127 STUD,PLAIN.

Weight and Dimensions

National Stock Number

Box Weight	Box Size	Item Weight	Item Dimensions	FSC	FSG	NIIN	INC
.3lbs	--	--	--	5307	53	01-236-5127 / 012365127	15948

National Motor Freight / Schedule B

NMFC	Description	Schedule B
093486	BOLTS,NUTS OR SCREWS, (SUB 3)	

MV83523TS446V

Grooved Clamp Coupling

BAND THICKNESS:	0.030 INCHES NOMINAL
BAND WIDTH:	0.750 INCHES NOMINAL
CROSS-SECTIONAL SHAPE STYLE:	GROOVED RETAINER
HEIGHT:	0.281 INCHES NOMINAL
NUT TYPE:	SELF-LOCKING HEXAGON
INCLUDED ANGLE IN DEG:	40.0
INSIDE DIAMETER:	4.460 INCHES NOMINAL
LATCH STYLE:	SINGLE
MATERIAL AND LOCATION:	STEEL, AISI 301 BAND
MATERIAL AND LOCATION:	STEEL, AISI 301 SEGMENT
MATERIAL AND LOCATION:	STEEL, CORROSION RESISTING NUT
MATERIAL AND LOCATION:	STEEL, MIL-S-7720 BOLT
RETAINER THICKNESS:	0.040 INCHES NOMINAL
RETAINER WIDTH:	0.620 INCHES NOMINAL
ROOT WIDTH:	0.181 INCHES NOMINAL
SEALING INNER LINER:	NOT INCLUDED
SEGMENT QUANTITY:	2

Weight and Dimensions

Box Weight	Box Size	Item Weight	Item Dimensions
.3lbs	--	--	--

National Motor Freight / Schedule B

National Stock Number

NMFC	Description	Schedule B	FSC	FSG	NIIN	INC
095190	HARDWARE, SUB 9	9803200000 / Military equipments not identified by kind	5342	53	01-073-1579 / 010731579	20319

C596-121A

General Purpose Resilient Mount

HARDWARE, COMMERCIAL NATIONAL STOCK NUMBER 5340-01-594-3711 MOUNT,RESILIENT,GENERAL PURPOSE.

National Stock Number

FSC	FSG	NIIN	INC
5340	53	01-594-3711 / 015943711	53590

114S2570-41Z

Packing Material

CROSS-SECTIONAL HEIGHT: 2.700 INCHES NOMINAL
CROSS-SECTIONAL SHAPE STYLE: RECTANGULAR
CROSS-SECTIONAL WIDTH: 0.063 INCHES NOMINAL
MATERIAL: RUBBER SYNTHETIC P0-650 FSCM 03938
LENGTH: 282.000 INCHES NOMINAL

Weight and Dimensions

National Stock Number

Box Weight	Box Size	Item Weight	Item Dimensions	FSC	FSG	NIIN	INC
A200.0lbs	--	--	--	5330	53	00-103-5004 / 001035004	04531

National Motor Freight / Schedule B

NMFC	Description	Schedule B
194120	WASHERS/GASKETS/PCKG DVCS	

70210-05001-122

Special Stud

GENERAL CHARACTERISTICS ITEM DESCRIPTION:

OVERALL LENGTH,0.770 IN.;THREAD 10-32 UNF-3A;MATERIAL,ALLOY STEEL

Weight and Dimensions

National Stock Number

Box Weight	Box Size	Item Weight	Item Dimensions	FSC	FSG	NIIN	INC
.1lbs	--	--	--	5307	53	01-096-1380 / 010961380	7777

National Motor Freight / Schedule B

NMFC	Description	Schedule B
093486	BOLTS,NUTS OR SCREWS, (SUB 3)	

SMC877301

Cover Protective

HARDWARE, WEAPON SYSTEM NATIONAL STOCK NUMBER 5342-01-088-2691 PROTECTIVE,COVER.

Weight and Dimensions

National Stock Number

Box Weight	Box Size	Item Weight	Item Dimensions	FSC	FSG	NIIN	INC
.1lbs	--	--	--	5342	53	01-088-2691 / 010882691	77777

National Motor Freight / Schedule B

NMFC	Description	Schedule B
095190	HARDWARE, SUB 9	

MIL-H-15021 TY 1

Snap Hook

END CONNECTION STYLE:	SWIVEL
CONNECTION END MATERIAL:	BRASS
DESIGN TYPE:	SWIVEL
HOOK MATERIAL:	BRASS
HOOK STYLE DESIGNATOR:	SLIDING BOLT
INSIDE WIDTH:	0.750 INCHES NOMINAL
RUBBER COVERED FEATURE:	NOT INCLUDED
OVERALL LENGTH:	3.500 INCHES NOMINAL
UNATTACHED RING:	INCLUDED

Weight and Dimensions

National Stock Number

Box Weight	Box Size	Item Weight	Item Dimensions	FSC	FSG	NIIN	INC
.2lbs	--	--	--	5340	53	00-275-4584 / 002754584	16954

National Motor Freight / Schedule B

NMFC	Description	Schedule B
095370	HOOKS I/S GALVANIZE/PLAIN ETC	

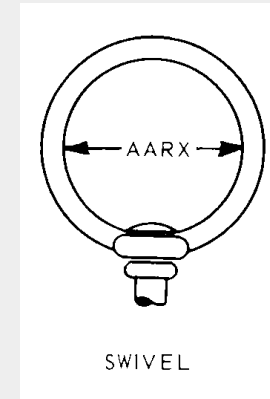

11460539-3

Rim Latch

HARDWARE, COMMERCIAL NATIONAL STOCK NUMBER 5340-01-254-1601 LATCH,RIM.

Weight and Dimensions

National Stock Number

Box Weight	Box Size	Item Weight	Item Dimensions	FSC	FSG	NIIN	INC
1.2lbs	--	--	--	5340	53	01-254-1601 / 012541601	06623

National Motor Freight / Schedule B

NMFC	Description	Schedule B
095190	HARDWARE, SUB 9	

11460539-4

Rim Latch

HARDWARE, COMMERCIAL NATIONAL STOCK NUMBER 5340-01-254-1600 LATCH,RIM.

Weight and Dimensions

National Stock Number

Box Weight	Box Size	Item Weight	Item Dimensions	FSC	FSG	NIIN	INC
1.4lbs	--	--	--	5340	53	01-254-1600 / 012541600	06623

National Motor Freight / Schedule B

NMFC	Description	Schedule B
095190	HARDWARE, SUB 9	

NAS1758110

Extended Washer Self-locking Nut

HARDNESS RATING:	45.0 ROCKWELL C MAXIMUM
MATERIAL:	STEEL COMP H11 OVERALL
NOMINAL THREAD SIZE:	0.625 INCHES
NUT STYLE:	DOUBLE HEXAGON
OVERALL HEIGHT:	0.740 INCHES MAXIMUM
LOCKING FEATURE:	PREVAILING TORQUE ALL METAL DESIGN
LUBRICATION:	DRY FILM LUBRICANT
WASHER OUTSIDE DIAMETER:	1.050 INCHES MAXIMUM
WASHER THICKNESS:	0.095 INCHES MINIMUM
WIDTH ACROSS FLATS:	0.741 INCHES MINIMUM AND 0.752 INCHES MAXIMUM
SURFACE TREATMENT DOCUMENT AND CLASSIFICATION:	AMS 2401-3 ASSN STD SINGLE TREATMENT RESPONSE OVERALL
SURFACE TREATMENT:	CADMIUM OVERALL
TEMP RATING:	450.0 DEG FAHRENHEIT NOMINAL
THREAD CLASS:	3B
THREAD DIRECTION:	RIGHT-HAND
THREAD QUANTITY PER INCH:	18
THREAD SERIES:	UNJF

Weight and Dimensions

National Stock Number

Box Weight	Box Size	Item Weight	Item Dimensions	FSC	FSG	NIIN	INC
.1lbs	--	--	--	5310	53	01-043-0045 / 010430045	29729

National Motor Freight / Schedule B

NMFC	Description	Schedule B
093486	BOLTS,NUTS OR SCREWS, (SUB 3)	7318160000 / Nuts of iron or steel

FDC1575-250-2

Webbing Strap

HARDWARE, COMMERCIAL NATIONAL STOCK NUMBER 5340-01-475-0615 STRAP,WEBBING.

Weight and Dimensions

National Stock Number

Box Weight	Box Size	Item Weight	Item Dimensions	FSC	FSG	NIIN	INC
--	--	--	--	5340	53	01-475-0615 / 014750615	20659

National Motor Freight / Schedule B

NMFC	Description	Schedule B
095190	HARDWARE,	

114109-750SS-12

Machine Screw

END ITEM IDENTIFICATION:

DSESTS BRADLEY A3

SCREW SURFACE TREATMENT:

PASSIVATE

PART NAME ASSIGNED BY CONTROLLING AGENCY:

SCREW, MACHINE, CAPTIVE, HEX HEAD

SPECIAL FEATURES:

MATERIAL: STAINLESS STEEL 18-8, 302-304 SERIES

Weight and Dimensions

National Stock Number

Box Weight	Box Size	Item Weight	Item Dimensions	FSC	FSG	NIIN	INC
.1lbs	--	--	--	5305	53	01-485-6547 / 014856547	06657

National Motor Freight / Schedule B

NMFC	Description	Schedule B
093486	BOLTS,NUTS OR SCREWS, (SUB 3)	

MIL-H-15021 TY 1

Snap Hook

END CONNECTION STYLE:	SWIVEL
CONNECTION END MATERIAL:	BRASS
DESIGN TYPE:	SWIVEL
HOOK MATERIAL:	BRASS
HOOK STYLE DESIGNATOR:	SLIDING BOLT
INSIDE WIDTH:	0.750 INCHES NOMINAL
RUBBER COVERED FEATURE:	NOT INCLUDED
OVERALL LENGTH:	3.500 INCHES NOMINAL
UNATTACHED RING:	INCLUDED

Weight and Dimensions

National Stock Number

Box Weight	Box Size	Item Weight	Item Dimensions	FSC	FSG	NIIN	INC
.2lbs	--	--	--	5340	53	00-275-4584 / 002754584	16954

National Motor Freight / Schedule B

NMFC	Description	Schedule B
095370	HOOKS I/S GALVANIZE/PLAIN ETC	

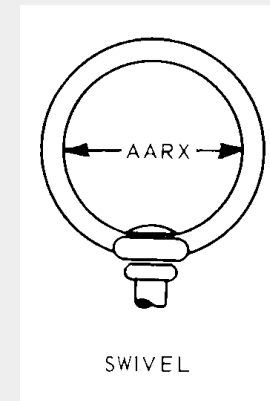

932-214-25

Headless Straight Pin

NAILS, MACHINE KEYS, AND PINS NATIONAL STOCK NUMBER 5315-01-458-8060 PIN,STRAIGHT,HEADLESS.

Weight and Dimensions

National Stock Number

Box Weight	Box Size	Item Weight	Item Dimensions	FSC	FSG	NIIN	INC
--	--	--	--	5315	53	01-458-8060 / 014588060	02390

National Motor Freight / Schedule B

NMFC	Description	Schedule B
095190	HARDWARE IRON/STEEL	

5340-01-212-4987

Headless Straight Rod

MATERIAL DOCUMENT AND CLASSIFICATION: QQ-N-288, COMP B FED SPEC 1ST MATERIAL RESPONSE OVERALL OR QQ-N-286, CLASS A FED SPEC 2ND MATERIAL RESPONSE OVERALL

MATERIAL: NICKEL ALLOY OVERALL

OVERALL DIAMETER: 0.873 INCHES MINIMUM AND 0.875 INCHES MAXIMUM

OVERALL LENGTH: 15.312 INCHES NOMINAL

Weight and Dimensions

National Stock Number

Box Weight	Box Size	Item Weight	Item Dimensions	FSC	FSG	NIIN	INC
2.8lbs	--	--	--	5340	53	01-212-4987 / 012124987	21876

National Motor Freight / Schedule B

NMFC	Description	Schedule B
139780	NICKEL ARTICLES	

5315-01-493-5378

Headed Straight Pin

NAILS, MACHINE KEYS, AND PINS NATIONAL STOCK NUMBER 5315-01-493-5378 PIN,STRAIGHT,HEADED.

Weight and Dimensions

National Stock Number

Box Weight	Box Size	Item Weight	Item Dimensions	FSC	FSG	NIIN	INC
--		--	--	5315	53	01-493-5378 / 014935378	02384

National Motor Freight / Schedule B

NMFC	Description	Schedule B
095190	HARDWARE,	7319409000 / Pins of iron or steel nesoi

9175609

Clamping Catch

CATCH WIDTH:	1.594 INCHES NOMINAL
DESIGN TYPE:	CLAW ENGAGING
ENGAGING SURFACE WIDTH:	1.875 INCHES NOMINAL
HOLE DIAMETER:	0.196 INCHES NOMINAL
HOLE QUANTITY:	4
MATERIAL:	STEEL BODY
MATERIAL:	STEEL CORROSION RESISTING LEVER
OPERATION METHOD:	WING NUT
OVERALL HEIGHT:	0.719 INCHES NOMINAL
OVERALL LENGTH:	3.406 INCHES NOMINAL
WING NUT WIDTH:	2.750 INCHES NOMINAL
STYLE DESIGNATOR:	SPECIAL

Weight and Dimensions

National Stock Number

Box Weight	Box Size	Item Weight	Item Dimensions	FSC	FSG	NIIN	INC
.3lbs	--	--	--	5340	53	00-600-5409 / 006005409	26525

National Motor Freight / Schedule B

NMFC	Description	Schedule B
095190	HARDWARE,	

MS24380-6SU

Swivel Caster

HARDWARE, COMMERCIAL NATIONAL STOCK NUMBER 5340-01-529-6190 CASTER,SWIVEL.

Weight and Dimensions

National Stock Number

Box Weight	Box Size	Item Weight	Item Dimensions	FSC	FSG	NIIN	INC
--	--	--	--	5340	53	01-529-6190 / 015296190	06188

National Motor Freight / Schedule B

NMFC	Description	Schedule B
041725	CASTERS IN BAGS/BBL/BX	8302200000 / Castors, and parts thereof, of base metal

20063173

Ring Spacer

END ITEM IDENTIFICATION:	LANDING GEAR SYSTEMS/COMPONENTS
CRITICALITY CODE JUSTIFICATION:	ADUM
MATERIAL:	STEEL COMP 302
OUTSIDE DIAMETER:	4.000 INCHES NOMINAL
INSIDE DIAMETER:	3.502 INCHES MINIMUM AND 3.508 INCHES MAXIMUM
OVERALL THICKNESS:	0.094 INCHES NOMINAL
PART NAME ASSIGNED BY CONTROLLING AGENCY:	SHIM-ROTATING LINKAGE, MLG
SPECIAL FEATURES:	HALF CIRCLE,GENERAL SHAPE

Weight and Dimensions

National Stock Number

Box Weight	Box Size	Item Weight	Item Dimensions	FSC	FSG	NIIN	INC
--	--	--	--	5365	53	01-058-9950 / 010589950	24307

National Motor Freight / Schedule B

NMFC	Description	Schedule B
106940	SPACERS/SEPARATORS I/S TUBULAR	

8110-366Y

O-ring

CENTER HOLE DIAMETER: 0.357 INCHES MINIMUM AND 0.367 INCHES MAXIMUM
CROSS-SECTIONAL HEIGHT: 0.100 INCHES MINIMUM AND 0.106 INCHES MAXIMUM
MATERIAL: RUBBER SYNTHETIC

Weight and Dimensions

National Stock Number

Box Weight	Box Size	Item Weight	Item Dimensions	FSC	FSG	NIIN	INC
--	--	--	--	5331	53	01-421-1541 / 014211541	47946

National Motor Freight / Schedule B

NMFC	Description	Schedule B
194120	WASHERS/GASKETS/PCKG DVCS	4016930000 / Gaskets, washers and other seals, of vulcanized rubber other than hard rubber

3113AS1321-1

Gasket

APERTURE DIAMETER:	6.620 INCHES NOMINAL
CROSS-SECTIONAL THICKNESS:	0.380 INCHES NOMINAL
CROSS-SECTIONAL SHAPE STYLE:	HOLLOW
MATERIAL DOCUMENT AND CLASSIFICATION:	ZZ-R-765 CLASS 2B, GRADE 25 FED SPEC ALL MATERIAL RESPONSES OVERALL
MATERIAL:	RUBBER SILICONE CLASS Q INSERT
MATERIAL:	RUBBER SILICONE CLASS Q OUTER RING
OUTSIDE DIAMETER:	7.380 INCHES NOMINAL
SPECIAL FEATURES:	CONSISTS OF HOLLOW TUBE AND JOINING ROD CEMENTED TOGETHER WITH MIL-A-46146 TYPE 3 ADHESIVE
STYLE DESIGNATOR:	CIRCULAR

Weight and Dimensions

National Stock Number

Box Weight	Box Size	Item Weight	Item Dimensions	FSC	FSG	NIIN	INC
--	--	--	--	5330	53	01-396-8092 / 013968092	04522

National Motor Freight / Schedule B

NMFC	Description	Schedule B
194050	GASKETS/RINGS PLUMBING FIXTURES	

TT375-A1B1

Knob

DISTANCE FROM HOLE CENTER TO KNOB/SKIRT BASE:	0.250 INCHES NOMINAL
ATTACHMENT METHOD:	SETSCREWS
COLOR:	BLACK
GRIPPING SURFACE CONDITION:	SMOOTH
MATERIAL TRANSPARENCY:	CLEAR
MATERIAL:	PLASTIC
NOMINAL THREAD SIZE:	0.112 INCHES SCREW HOLE
OUTSIDE DIAMETER:	0.620 INCHES NOMINAL
OVERALL DEPTH:	0.500 INCHES MAXIMUM
INSIDE DIAMETER:	0.260 INCHES NOMINAL
SCREW DRIVE TYPE:	HEXAGON SOCKET
SETSCREW HOLE QUANTITY:	2
SHAFT ACCOMMODATION STYLE:	ROUND
OVERALL THICKNESS:	0.560 INCHES NOMINAL
STYLE DESIGNATOR:	SKIRTED/ROUND WITH CONCAVE TOP
THREAD QUANTITY PER INCH:	40 SCREW HOLE
THREAD SERIES DESIGNATOR:	UNC SCREW HOLE

Weight and Dimensions

Box Weight	Box Size	Item Weight	Item Dimensions
1.0lbs	--	--	--

National Motor Freight / Schedule B

NMFC	Description	Schedule B
------	-------------	------------

108590

KNOBS/PULLS
DOOR/DRAWER

8531900002 / Parts of electric sound or visual
signaling apparatus other than printed circuit
assemblies

National Stock Number

FSC	FSG	NIIN	INC
5355	53	01-244-4572 / 012444572	03263

74D291008-2017

Knob

KNOBS AND POINTERS NATIONAL STOCK NUMBER 5355-01-596-9902 KNOB.

National Stock Number

FSC	FSG	NIIN	INC
5355	53	01-596-9902 / 015969902	03263

5331-00-412-9908

O-ring

CENTER HOLE DIAMETER: 7.583 INCHES MINIMUM AND 7.643 INCHES MAXIMUM
CROSS-SECTIONAL HEIGHT: 0.067 INCHES MINIMUM AND 0.073 INCHES MAXIMUM
MATERIAL: RUBBER BUTADIENE-ACRYLONITRILE CLASS NBR

Weight and Dimensions

National Stock Number

Box Weight	Box Size	Item Weight	Item Dimensions	FSC	FSG	NIIN	INC
.1lbs	--	--	--	5331	53	00-412-9908 / 004129908	47946

National Motor Freight / Schedule B

NMFC	Description	Schedule B
194120	WASHERS/GASKETS/PCKG DVCS	4016930000 / Gaskets, washers and other seals, of vulcanized rubber other than hard rubber

10190486-1

Shim

APERTURE DIAMETER:	0.385 INCHES MINIMUM AND 0.392 INCHES MAXIMUM
CONSTRUCTION:	LAMINATED
FEATURES PROVIDED:	SEPARABLE
MATERIAL DOCUMENT AND CLASSIFICATION:	QQ-S-766 FED SPEC SINGLE MATERIAL RESPONSE OR MIL-S-5059 MIL SPEC SINGLE MATERIAL RESPONSE
MATERIAL:	STEEL COMP 302
OUTSIDE DIAMETER:	0.780 INCHES NOMINAL
LAMINATION QUANTITY:	78
LAMINATION THICKNESS:	0.002 INCHES NOMINAL
STYLE DESIGNATOR:	CIRCULAR

Weight and Dimensions

National Stock Number

Box Weight	Box Size	Item Weight	Item Dimensions	FSC	FSG	NIIN	INC
.1lbs	--	--	--	5365	53	01-006-0496 / 010060496	20349

National Motor Freight / Schedule B

NMFC	Description	Schedule B
133300	MACHINERY/MACHINES	7326908595 / Other articles of iron or steel not wire nesoi

50B25174-1

O-ring

ELONGATION PERCENTAGE: 160 MAXIMUM
 CENTER HOLE DIAMETER: 4.255 INCHES MINIMUM AND 4.285 INCHES MAXIMUM
 CROSS-SECTIONAL HEIGHT: 0.529 INCHES MINIMUM AND 0.549 INCHES MAXIMUM
 MATERIAL: RUBBER BUTADIENE-ACRYLONITRILE CLASS NBR

Weight and Dimensions

National Stock Number

Box Weight	Box Size	Item Weight	Item Dimensions	FSC	FSG	NIIN	INC
.2lbs	--	--	--	5331	53	00-090-0717 / 000900717	47946

National Motor Freight / Schedule B

NMFC	Description	Schedule B
194120	WASHERS/GASKETS/PCKG DVCS	4016930000 / Gaskets, washers and other seals, of vulcanized rubber other than hard rubber

74D291008-2017

Knob

KNOBS AND POINTERS NATIONAL STOCK NUMBER 5355-01-596-9902 KNOB.

National Stock Number

FSC	FSG	NIIN	INC
5355	53	01-596-9902 / 015969902	03263

8438717

Loop Clamp

DISTANCE FROM OUTER EDGE OF LUG TO HOLE CENTER:	0.234 INCHES MINIMUM AND 0.250 INCHES MAXIMUM
DISTANCE FROM LOOP CENTER TO TONGUE END:	1.093 INCHES NOMINAL
CENTER TO CENTER DISTANCE BETWEEN LOOP AND LUG HOLE:	1.539 INCHES NOMINAL
CENTER TO CENTER DISTANCE BETWEEN LOOP AND MOUNTING HOLE:	0.875 INCHES NOMINAL
DIAMETER:	0.199 INCHES MINIMUM AND 0.209 INCHES MAXIMUM
MATERIAL THICKNESS:	0.046 INCHES MINIMUM AND 0.056 INCHES MAXIMUM
MATERIAL:	RUBBER CHLOROPRENE CLASS CR CUSHION
INTEGRAL NUT TYPE AND QUANTITY:	1 SELF-LOCKING EQUAL LENGTH TONGUES
LOOP INSIDE DIAMETER:	1.235 INCHES MINIMUM AND 1.265 INCHES MAXIMUM
LUG WIDTH:	0.484 INCHES MINIMUM AND 0.516 INCHES MAXIMUM
LUG HOLE DIAMETER:	0.199 INCHES MINIMUM AND 0.209 INCHES MAXIMUM
MATERIAL DOCUMENT AND CLASSIFICATION:	AMS3209 ASSN STD SINGLE MATERIAL RESPONSE CUSHION OR 417GRADESC715 MIL STD SINGLE MATERIAL RESPONSE CUSHION
OVERALL WIDTH:	0.484 INCHES MINIMUM AND 0.516 INCHES MAXIMUM
STYLE DESIGNATOR:	RIGHT HAND CLAMP & BRACKET
SURFACE TREATMENT DOCUMENT AND CLASSIFICATION:	QQ-P-416, TY 1, CL 2 FED SPEC SINGLE TREATMENT RESPONSE BAND
SURFACE TREATMENT:	CADMIUM BAND
TONGUE HOLE TYPE:	ROUND, UNTHREADED

Weight and Dimensions

National Stock Number

Box Weight	Box Size	Item Weight	Item Dimensions	FSC	FSG	NIIN	INC
--	--	--	--	5340	53	00-251-4623 / 002514623	17532

National Motor Freight / Schedule B

NMFC	Description	Schedule B
095190	HARDWARE, SUB 9	

101026

Knob

KNOBS AND POINTERS NATIONAL STOCK NUMBER 5355-01-471-8347 KNOB.

National Stock Number

FSC	FSG	NIIN	INC
5355	53	01-471-8347 / 014718347	03263

N5000-450

Retaining Ring

CROSS-SECTIONAL SHAPE STYLE:	RECTANGULAR
MATERIAL:	STEEL, CARBON
OUTSIDE DIAMETER:	4.940 INCHES NOMINAL
MAJOR THICKNESS:	0.109 INCHES NOMINAL
RING STYLE:	INTERNAL
SURFACE TREATMENT:	PHOSPHATE COATED
USAGE DESIGN:	INTERNAL

National Stock Number

FSC	FSG	NIIN	INC
5325	53	01-362-8198 / 013628198	07623

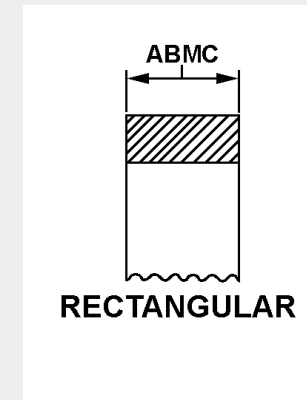

BLS10LA40S

Quick Release Pin

MATERIAL:

STEEL COMP 4130 OVERALL

SPECIAL FEATURES:

SHANK .625 INCHES

National Stock Number

FSC	FSG	NIIN	INC
5315	53	01-489-0475 / 014890475	08323

40S37-10A

Lock Pin Fastener Stud

FASTENING DEVICES NATIONAL STOCK NUMBER 5325-01-371-1975 STUD,LOCK PIN FASTENER.

National Stock Number

FSC	FSG	NIIN	INC
5325	53	01-371-1975 / 013711975	18531

7013MR-964-T

Packing Assembly

CROSS-SECTIONAL SHAPE STYLE:	SQUARE/RECTANGULAR BOTTOM RING
CROSS-SECTIONAL SHAPE STYLE:	SQUARE/RECTANGULAR TOP RING
CROSS-SECTIONAL SHAPE STYLE:	TEE INTERMEDIATE RING
HEIGHT:	0.025 INCHES NOMINAL
MATERIAL:	RUBBER FLUOROPHOSPHONITRILIC INTERMEDIATE RING
MATERIAL:	PLASTIC POLYTETRAFLUOROETHYLENE BOTTOM RING
MATERIAL:	PLASTIC POLYTETRAFLUOROETHYLENE TOP RING
OUTSIDE DIAMETER:	0.550 INCHES NOMINAL
INSIDE DIAMETER:	0.433 INCHES NOMINAL
INTERMEDIATE RING QUANTITY:	1
JOINT TYPE:	SCARF-PERIPHERAL BOTTOM RING
JOINT TYPE:	SCARF-PERIPHERAL TOP RING
MATERIAL DOCUMENT AND CLASSIFICATION:	MIL-P-87175 MIL SPEC SINGLE MATERIAL RESPONSE INTERMEDIATE RING
MATERIAL DOCUMENT AND CLASSIFICATION:	MIL-R-8791 MIL SPEC SINGLE MATERIAL RESPONSE BOTTOM RING
MATERIAL DOCUMENT AND CLASSIFICATION:	MIL-R-8791 MIL SPEC SINGLE MATERIAL RESPONSE TOP RING

Weight and Dimensions

National Stock Number

Box Weight	Box Size	Item Weight	Item Dimensions	FSC	FSG	NIIN	INC
.1lbs	--	--	--	5330	53	01-264-1656 / 012641656	07961

National Motor Freight / Schedule B

NMFC	Description	Schedule B
194120	WASHERS/GASKETS/PCKG DVCS	

S30631-016-99

Plain Seal

PACKING AND GASKET MATERIALS NATIONAL STOCK NUMBER 5330-01-333-6928 SEAL,PLAIN.

Weight and Dimensions

National Stock Number

Box Weight	Box Size	Item Weight	Item Dimensions	FSC	FSG	NIIN	INC
.1lbs	--	--	--	5330	53	01-333-6928 / 013336928	04250

National Motor Freight / Schedule B

NMFC	Description	Schedule B
194050	GASKETS/RINGS PLUMBING FIXTURES	3926904500 / Gaskets,washers & other seals

5350002424406

Metallic Wool

PHYSICAL FORM: ROLL
SPECIAL FEATURES: COARSE GRADE, STEEL, USED FOR CLEANING AND POLISHING
SUPPLEMENTARY FEATURES: THICKNESS .001IN.; CORROSION RESISTENCE; ELASTICITY SHAPE - 85 PERCENT; SIZE - 14 TO 16IN. (360MM TO 410MM) LONG PRIOR TO FORMING SHAPE

National Motor Freight / Schedule B

National Stock Number

NMFC	Description	Schedule B	FSC	FSG	NIIN	INC
200160	WOOL STEEL	7323100000 / Iron or steel wool; pot scourers and scouring or polishing pads, gloves and the like, of iron or steel	5350	53	00-242-4406 / 002424406	30248

BDS3115-009CH/3

O-ring

O-RINGS NATIONAL STOCK NUMBER 5331-01-127-6940 O-RING.

Weight and Dimensions

National Stock Number

Box Weight	Box Size	Item Weight	Item Dimensions	FSC	FSG	NIIN	INC
.1lbs	--	--	--	5331	53	01-127-6940 / 011276940	47946

National Motor Freight / Schedule B

NMFC	Description	Schedule B
194120	WASHERS/GASKETS/PCKG DVCS	

51446-8L87

Quick Release Pin

GRIP LENGTH: 87.0 MILLIMETERS NOMINAL
MATERIAL: STEEL HANDLE
SHANK DIAMETER: 8.0 MILLIMETERS NOMINAL

National Stock Number

FSC	FSG	NIIN	INC
5315	53	01-419-1732 / 014191732	08323

NW15181

Gasket

END ITEM IDENTIFICATION:

SPECIAL AIRCRAFT AND ENGINE TOOL AND SUPPORT EQUIPMENT AND PARTS

National Motor Freight / Schedule B

National Stock Number

NMFC	Description	Schedule B	FSC	FSG	NIIN	INC
194130	WASHERS/GASKETS/MAINT I/C ENG SUB2		5330	53	01-420-1476 / 014201476	04522

BLC7TA30S

Quick Release Pin

ACTUATION METHOD:	PUSH BUTTON
ACTUATION TYPE:	PUSH
DETENT QUANTITY:	2
DETENT TO TAPERED END DISTANCE:	0.350 INCHES MINIMUM AND 0.380 INCHES MAXIMUM
GRIP LENGTH:	3.000 INCHES MINIMUM AND 3.020 INCHES MAXIMUM
HANDLE LENGTH:	1.935 INCHES MINIMUM AND 2.065 INCHES MAXIMUM
HARDNESS RATING:	40.0 ROCKWELL C MINIMUM SHANK
HARDNESS RATING:	40.0 ROCKWELL C MINIMUM SPINDLE
MATERIAL:	STEEL COMP 630 SHANK OR STEEL COMP 632 SHANK
MATERIAL:	STEEL COMP 630 SPINDLE OR STEEL COMP 632 SPINDLE
MATERIAL DOCUMENT AND CLASSIFICATION:	AMS 5643 ASSN STD 1ST MATERIAL RESPONSE SHANK OR AMS 5657 ASSN STD 2ND MATERIAL RESPONSE SHANK
MATERIAL DOCUMENT AND CLASSIFICATION:	AMS 5643 ASSN STD 1ST MATERIAL RESPONSE SPINDLE OR AMS 5657 ASSN STD 2ND MATERIAL RESPONSE SPINDLE
SHANK DIAMETER:	0.4345 INCHES MINIMUM AND 0.4360 INCHES MAXIMUM
SHOULDER TO HEAD END DISTANCE:	1.470 INCHES MAXIMUM
PIN ATTACHMENT TYPE:	HOOK OR RING
STYLE DESIGNATOR:	T HANDLE
SURFACE TREATMENT DOCUMENT AND CLASSIFICATION:	QQ-P-35 FED SPEC SINGLE TREATMENT RESPONSE SHANK

Weight and Dimensions

National Stock Number

Box Weight	Box Size	Item Weight	Item Dimensions	FSC	FSG	NIIN	INC
.2lbs	--	--	--	5315	53	00-938-9104 / 009389104	08323

National Motor Freight / Schedule B

NMFC	Description	Schedule B
095190	HARDWARE, SUB 9	

2007608-1

Plate Spacer

END ITEM IDENTIFICATION: NLG SHOCK STRUT,F-16
BEARING SURFACE WIDTH: 0.120 INCHES NOMINAL
CRITICALITY CODE JUSTIFICATION: SUPP
MATERIAL: ALUMINUM ALLOY 2024
MATERIAL DOCUMENT AND CLASSIFICATION: QQ-A-200/3 T3511 FED SPEC 1ST MATERIAL RESPONSE OR QQ-A-225/6 T351 FED SPEC 2ND MATERIAL RESPONSE
SLOT LENGTH: 0.180 INCHES NOMINAL
SLOT QUANTITY: 1
SLOT WIDTH: 0.070 INCHES MINIMUM AND 0.080 INCHES MAXIMUM
SPECIAL FEATURES: HALF RING,OD HAS CENTRALLY LOCATED GROOVE W 0.035 IN. RADIUS; SLOT LOCATED IN GROOVE
SUPPLEMENTARY FEATURES: THIS ITEM IS CRITICAL TO APPLICATION,F-16 LANDING GEAR COMPONENT,AND IS ESSENTIAL TO WEAPON SYSTEM PERFORMANCE AND OPERATION
SURFACE TREATMENT DOCUMENT AND CLASSIFICATION: MIL-A-8625 MIL SPEC SINGLE TREATMENT RESPONSE
SURFACE TREATMENT: ANODIZE

Weight and Dimensions

National Stock Number

Box Weight	Box Size	Item Weight	Item Dimensions	FSC	FSG	NIIN	INC
.1lbs	--	--	--	5365	53	01-256-4240 / 012564240	26979

National Motor Freight / Schedule B

NMFC	Description	Schedule B
194120	WASHERS/GASKETS/PCKG DVCS	7616995095 / Articles of aluminum nesoi

PCIe-GIE62+

Aircr Ethernet Card

ELECTRICAL AND ELECTRONIC PROPERTIES MEASURING AND TESTING INSTRUMENTS NATIONAL STOCK NUMBER 6625-01-580-5093 ETHERNET CARD,AIRCR.

Weight and Dimensions

National Stock Number

Box Weight	Box Size	Item Weight	Item Dimensions	FSC	FSG	NIIN	INC
--	--	--	--	6625	66	01-580-5093 / 015805093	77777

6630-01-493-1758

Pocket Analysis Syst Colorimeter

MATERIAL: PLASTIC
OVERALL HEIGHT: 6.000 INCHES NOMINAL
OVERALL LENGTH: 1.250 INCHES NOMINAL
OVERALL WIDTH: 2.400 INCHES NOMINAL
PART NAME ASSIGNED BY CONTROLLING AGENCY: COLORIMETER

SPECIAL FEATURES: WEIGHT 0.43 POUNDS; LIGHT EMITTING DIODE, SILICONE PHOTOCELL, FIXED WAVELENGTH; POWER SUPPLY; 4 AAAA ALKALINE BATTERIES; APPROXIMATE LIFE IS 500 TESTES; DISPLAY: LIQUID CRYSTAL; OPERATING TEMPERATURE: 0 TO 50 DEGREES C; SUITABLE FOR FIELD STUDIES OR ON THE SPOT PROCESSING MONITORING; MEASURES EVEN LEVELS OF CONSTITUENTS IMPACTING WATER QUALITY

Weight and Dimensions

National Stock Number

Box Weight	Box Size	Item Weight	Item Dimensions	FSC	FSG	NIIN	INC
9.0lbs	--	--	--	6630	66	01-493-1758 / 014931758	7777

DB0218LW2

Frequency Mixer Stage

END ITEM IDENTIFICATION:	AN/USQ-149(V)2, TLS & SE
AVERAGE LIFE MEASUREMENT:	NOT RATED
BASIC SHAPE STYLE:	RECTANGULAR OR SQUARE
CONNECTION CONTACT TYPE AND QUANTITY:	3 CONNECTOR, PLUG EXTERNAL
CONNECTION TYPE AND LOCATION:	CONNECTOR, PLUG FRONT AND CONNECTOR, PLUG LEFT SIDE AND CONNECTOR, PLUG RIGHT SIDE
FREQUENCY PER CHANNEL:	2.0 GIGAHERTZ MINIMUM OPERATING CHANNEL ERR-100 AND 18.0 GIGAHERTZ MAXIMUM OPERATING CHANNEL ERR-100
III CIRCUIT CONSTRUCTION TYPE:	SOLID STATE
OVERALL HEIGHT:	0.280 INCHES NOMINAL
OVERALL LENGTH:	0.800 INCHES NOMINAL
INCLOSURE TYPE:	ENCASED
INDIVIDUAL SECTION QUANTITY:	1
INSTALLATION DESIGN:	MODULE
RELIABILITY INDICATOR:	NOT ESTABLISHED
OVERALL WIDTH:	0.590 INCHES NOMINAL
PART NAME ASSIGNED BY CONTROLLING AGENCY:	DOUBLE-BALANCED MIXER W/IF AMPLIFIERS
SPECIAL FEATURES:	SMA FIELD REPLACEABLE FEMALE CONNECTORS; RF VSWR: 1.5

Weight and Dimensions

National Stock Number

Box Weight	Box Size	Item Weight	Item Dimensions	FSC	FSG	NIIN	INC
--	--	--	--	6625	66	01-552-0171 / 015520171	00334

National Motor Freight / Schedule B

NMFC	Description	Schedule B
116030	MACHINES ETC DATA PROCESSING	

0406-004

Magneto Sensor

MATERIAL: ALUMINUM

SPECIAL FEATURES: 6-16 VDC EXCITATION VOLTAGE; 6061 ALUMINUM HOUSING; -40 TO 150 DEG C OPERATING TEMPERATURE; DIGITAL SIGNAL OUTPUT

National Stock Number

FSC	FSG	NIIN	INC
6680	66	01-580-5863 / 015805863	7777

030674-0001

Ambient Temperature Sensor

END ITEM IDENTIFICATION:

INSTRUMENT LANDING SYSTEM (ILS 2100)

PART NAME ASSIGNED BY CONTROLLING AGENCY:

TEMP SENSOR ASSY

National Stock Number

FSC	FSG	NIIN	INC
6685	66	01-522-4503 / 015224503	48909

DMH-1

Electronic Systems Test Set

END ITEM IDENTIFICATION:	C-135
CRITICALITY CODE JUSTIFICATION:	FEAT
INCLOSURE FEATURE:	SINGLE ITEM W/CARRYING CASE
LENGTH:	7.500 INCHES NOMINAL
SPECIAL FEATURES:	WEAPON SYSTEM ESSENTIAL
WIDTH:	4.000 INCHES NOMINAL
TEST TYPE FOR WHICH DESIGNED:	READING OF EA COMPONENT OF AIRCREW'S COMMUNICATION EQUIP,HEADSET,MICROPHONE,CORD
THICKNESS:	2.500 INCHES NOMINAL

Weight and Dimensions

National Stock Number

Box Weight	Box Size	Item Weight	Item Dimensions	FSC	FSG	NIIN	INC
1.9lbs	100 X 50 X 40	--	--	6625	66	01-251-8705 / 012518705	61201

National Motor Freight / Schedule B

NMFC	Description	Schedule B
061700	ELEC APPLIANCES/INSTRUMENTS	9030908030 / Parts and accessories of articles of schedule b subheading 9030.39

8103061

Detector Tube

END ITEM IDENTIFICATION:

BREATHING/AIR

SPECIAL FEATURES:

WATER VAPOR DETECTOR TUBE

Weight and Dimensions

National Stock Number

Box Weight	Box Size	Item Weight	Item Dimensions	FSC	FSG	NIIN	INC
.2lbs	--	--	--	6665	66	01-461-6678 / 014616678	7777

National Motor Freight / Schedule B

NMFC	Description	Schedule B
063476	TUBES SUB1	

8103111

Detector Tube

END ITEM IDENTIFICATION:

BREATHING/AIR

SPECIAL FEATURES:

WATER VAPOR DETECTOR TUBE

Weight and Dimensions

National Stock Number

Box Weight	Box Size	Item Weight	Item Dimensions	FSC	FSG	NIIN	INC
.2lbs	--	--	--	6665	66	01-461-6678 / 014616678	7777

National Motor Freight / Schedule B

NMFC	Description	Schedule B
063476	TUBES SUB1	

23066617

Borescope Kit

END ITEM IDENTIFICATION:

H-60 DYNAMIC COMPONENT CHANGE TECHNICAL DIRECTIVE COMPLIANCE KITS;SUPPORT EQUIPMENT FOR AE1107C ENGINE

PART NAME ASSIGNED BY CONTROLLING AGENCY:

(NAVY)SET,GUIDE TUBE,AIR

Weight and Dimensions

National Stock Number

Box Weight	Box Size	Item Weight	Item Dimensions	FSC	FSG	NIIN	INC
--	--	--	--	6650	66	01-527-6918 / 015276918	53182

National Motor Freight / Schedule B

NMFC	Description	Schedule B
062330	KITS/SETS ELEC INSTRUMENT ASSEMBLY	9018500000 / Other ophthalmic instruments and appliances and parts and accessories

6685-00-124-4336

Tire Inflator Assembly

GENERAL CHARACTERISTICS ITEM DESCRIPTION:

DIRECT READING,REMOTE CONTROL,PNEUMATIC PRESSUREINFLATOR ASSEMBLY

Weight and Dimensions

National Stock Number

Box Weight	Box Size	Item Weight	Item Dimensions	FSC	FSG	NIIN	INC
10.0lbs	200 X 100 X 60	--	--	6685	66	00-124-4336 / 001244336	7777

National Motor Freight / Schedule B

NMFC	Description	Schedule B
157227	PLASTIC/RUBR TIRES INNER SFTY SPARE	

ASC710KU-RC

Signal Data Translator Test Set

END ITEM IDENTIFICATION:

AN/TSC-202 STT-HP

National Stock Number

FSC	FSG	NIIN	INC
6625	66	01-617-0330 / 016170330	03674

17C061-P234

Plug Humidity Indicator

END ITEM IDENTIFICATION:

SHIPPING AND STORAGE

Weight and Dimensions

National Stock Number

Box Weight	Box Size	Item Weight	Item Dimensions	FSC	FSG	NIIN	INC
--	--	--	--	6685	66	01-537-7054 / 015377054	08357

National Motor Freight / Schedule B

NMFC	Description	Schedule B
121570	GAGES AIR LIQUID LEVEL PRESSURE	9025805050 / Hydrometers and similar floating instruments, hygrometers and psychrometers

6685-00-124-4336

Tire Inflator Assembly

GENERAL CHARACTERISTICS ITEM DESCRIPTION:

DIRECT READING,REMOTE CONTROL,PNEUMATIC PRESSUREINFLATOR ASSEMBLY

Weight and Dimensions

National Stock Number

Box Weight	Box Size	Item Weight	Item Dimensions	FSC	FSG	NIIN	INC
10.0lbs	200 X 100 X 60	--	--	6685	66	00-124-4336 / 001244336	7777

National Motor Freight / Schedule B

NMFC	Description	Schedule B
157227	PLASTIC/RUBR TIRES INNER SFTY SPARE	

6685-00-124-4336

Tire Inflator Assembly

GENERAL CHARACTERISTICS ITEM DESCRIPTION:

DIRECT READING,REMOTE CONTROL,PNEUMATIC PRESSUREINFLATOR ASSEMBLY

Weight and Dimensions

National Stock Number

Box Weight	Box Size	Item Weight	Item Dimensions	FSC	FSG	NIIN	INC
10.0lbs	200 X 100 X 60	--	--	6685	66	00-124-4336 / 001244336	7777

National Motor Freight / Schedule B

NMFC	Description	Schedule B
157227	PLASTIC/RUBR TIRES INNER SFTY SPARE	

D46C8H

Time Totalizing Meter

CURRENT TYPE: DC
MOVEMENT TYPE: ELECTRICAL
III INDICATOR TYPE: DIGITAL COUNTER
VOLTAGE RATING: 5.0 VOLTS NOMINAL

Weight and Dimensions

National Stock Number

Box Weight	Box Size	Item Weight	Item Dimensions	FSC	FSG	NIIN	INC
.2lbs	--	--	--	6645	66	01-324-1956 / 013241956	08066

National Motor Freight / Schedule B

NMFC	Description	Schedule B
136740	METERS ELEC/PARTS measuring, recording or otherwise indicating intervals of time	9106903000 / Other time of the day apparatus for

6625-01-068-8721

Fault Locating Indicator

CASE MATERIAL: PLASTIC

SPECIAL FEATURES: COIL VOLTAGE 28 V;MIN RES 1300 OHMS;PULSE LENGTH 20MS;OPERATING TEMP RANGE M 65 DEG C TO P 105 DEG C;BODY DIM:0.760 IN L;0.210 W;0.410 H

Weight and Dimensions

National Stock Number

Box Weight	Box Size	Item Weight	Item Dimensions	FSC	FSG	NIIN	INC
.1lbs	--	--	--	6625	66	01-068-8721 / 010688721	60639

National Motor Freight / Schedule B

NMFC	Description	Schedule B
146230	GUNS MACHINE/PARTS SM ARMS AMMO	9030908030 / Parts and accessories of articles of schedule b subheading 9030.39

6685-01-185-1246

Plug Humidity Indicator

NOMINAL THREAD SIZE:

0.750 INCHES SINGLE END

NONDEFINITIVE SPEC/STD DATA:

II TYPE

THREAD DIRECTION:

RIGHT-HAND SINGLE END

THREAD QUANTITY PER INCH:

14 SINGLE END

Weight and Dimensions

National Stock Number

Box Weight	Box Size	Item Weight	Item Dimensions	FSC	FSG	NIIN	INC
.1lbs	--	--	--	6685	66	00-004-8970 / 000048970	08357

National Motor Freight / Schedule B

NMFC	Description	Schedule B
121570	GAGES AIR LIQUID LEVEL PRESSURE	9025805050 / Hydrometers and similar floating instruments,hygrometers and psychrometers

2A-1D5

Phase Sequence Indicator

ELECTRICAL CONNECTION QUANTITY:	3
AC VOLTAGE RATING:	180.0 VOLTS MINIMUM AND 220.0 VOLTS MAXIMUM
CASE MATERIAL:	ALUMINUM
DIAMETER:	0.750 INCHES NOMINAL
DISPLAY TYPE:	LIGHT EMITTING DIODE
FREQUENCY RATING:	54.0 HERTZ MINIMUM AND 66.0 HERTZ MAXIMUM
MOUNTING FACILITY TYPE AND QUANTITY:	1 PANEL
LENGTH:	3.820 INCHES NOMINAL
PHASE:	THREE
PRESENTATION TYPE:	INDICATOR LIGHT

Weight and Dimensions

National Stock Number

Box Weight	Box Size	Item Weight	Item Dimensions	FSC	FSG	NIIN	INC
.1lbs	--	--	--	6625	66	01-363-3419 / 013633419	06489

National Motor Freight / Schedule B

NMFC	Description	Schedule B
061700	ELEC APPLIANCES/INSTRUMENTS	9030908030 / Parts and accessories of articles of schedule b subheading 9030.39

MS25331-2

Indicator Light

INDOOR AND OUTDOOR ELECTRIC LIGHTING FIXTURES NATIONAL STOCK NUMBER 6210-00-686-4999 LIGHT,INDICATOR.

Weight and Dimensions

National Stock Number

Box Weight	Box Size	Item Weight	Item Dimensions	FSC	FSG	NIIN	INC
.1lbs	--	--	--	6210	62	00-686-4999 / 006864999	00160

National Motor Freight / Schedule B

NMFC	Description	Schedule B
109700	LAMP OR LIGHTING FIXTURES	9405400000 / Electric lamps and lighting fittings

FX5340

Lamp Ballast

END ITEM IDENTIFICATION: FIXTURE, LIGHT
CURRENT TYPE: AC
FREQUENCY RATING: 50.0 HERTZ MINIMUM AND 60.0 HERTZ MAXIMUM
OVERALL HEIGHT: 6.53 INCHES NOMINAL
OVERALL LENGTH: 26.59 INCHES NOMINAL
OVERALL WIDTH: 15.72 INCHES NOMINAL
VOLTAGE RATING: 120.0 VOLTS MINIMUM AND 277.0 VOLTS MAXIMUM

Weight and Dimensions

National Stock Number

Box Weight	Box Size	Item Weight	Item Dimensions	FSC	FSG	NIIN	INC
--	--	--	--	6250	62	01-612-5366 / 016125366	05123

National Motor Freight / Schedule B

NMFC	Description	Schedule B
060630	BALLASTS LAMP	

351-38257-021

Indicator Light Assembly

END ITEM IDENTIFICATION: NVIS
MOUNTING METHOD: UNTHREADED HOLE
LENS LEGEND: (BLANK) 2ND ROW 2ND POSITION VERTICAL HORIZONTAL SPLIT DISPLAY DIVISION B
LENS LEGEND: EPU GEN 2ND ROW 3RD POSITION VERTICAL HORIZONTAL SPLIT DISPLAY DIVISION A
LENS LEGEND: EPU PMG 2ND ROW 3RD POSITION VERTICAL HORIZONTAL SPLIT DISPLAY DIVISION B
LENS LEGEND: FAIL 2ND ROW 4TH POSITION VERTICAL FULL DISPLAY DIVISION A
LENS LEGEND: FLCS RLY 1ST ROW 1ST POSITION VERTICAL HORIZONTAL SPLIT DISPLAY DIVISION B
LENS LEGEND: STBY GEN 2ND ROW 2ND POSITION VERTICAL HORIZONTAL SPLIT DISPLAY DIVISION A
LENS LEGEND: TO FLCS 1ST ROW 1ST POSITION VERTICAL HORIZONTAL SPLIT DISPLAY DIVISION A
LENS QUANTITY: 5
LENS TYPE: FLAT, RECTANGULAR 1ST ROW 1ST POSITION VERTICAL
LENS TYPE: FLAT, RECTANGULAR 1ST ROW 2ND POSITION VERTICAL
LENS TYPE: FLAT, RECTANGULAR 2ND ROW 3RD POSITION VERTICAL
LENS TYPE: FLAT, RECTANGULAR 2ND ROW 4TH POSITION VERTICAL
LENS TYPE: FLAT, RECTANGULAR 2ND ROW 1ST POSITION VERTICAL
LENS TYPE: FLAT, RECTANGULAR 2ND ROW 2ND POSITION VERTICAL
SPECIAL FEATURES: ITEM IS MADE FROM P/N 65-1067-7 (C4965-16)(CAGE 72914)BY REPLACING ORIGINAL CAP ASSEMBLIES;WSD IS F-16 AIRCRAFT

Weight and Dimensions

Box Weight	Box Size	Item Weight	Item Dimensions
.5lbs	--	--	--

National Motor Freight / Schedule B

National Stock Number

NMFC	Description	Schedule B	FSC	FSG	NIIN	INC
109700	LAMP OR LIGHTING FIXTURES	9405400000 / Electric lamps and lighting fittings	6210	62	01-473-2410 / 014732410	03430

8739551

Electric Floodlight

END ITEM IDENTIFICATION:	AUSTIN SHIP CLASS LPD-4 AMPHIBIOUS TRANSPORT DOCKS; TRUCK, CARGO, 5-TON, 6X6, XLWB W/E; CARGO SYSTEM, 463L; ASSAULT AMPHIBIOUS VEHICLE, COMMAND (AAVC-7A1); SHIPBOARD MATERIAL HANDLING EQUIPMENT (MHE); LAV, ANTI-TANK; FAMILY OF MEDIUM TACTICAL VEHICLES-MEDIUM; WASP CLASS LHD; TRUCK, WRECKER, 5-TON (M936)
DEPARTURE FROM CITED DOCUMENT:	AS MODIFIED BY THEADAPTER KIT
FURNISHED ITEMS AND QUANTITY:	1 LAMP
FEATURES PROVIDED:	SWITCH
HAZARDOUS LOCATIONS/ENVIRONMENTAL PROTECTION:	ANY ACCEPTABLE
MATERIAL:	ANY ACCEPTABLE BODY
MOUNTING METHOD:	THREADED STUD
OVERALL DIAMETER:	6.250 INCHES NOMINAL
OVERALL HEIGHT:	11.500 INCHES NOMINAL
LAMP BASE TYPE ACCOMMODATED:	TWO SCREW TERMINALS
LAMP TYPE ACCOMMODATED AND QUANTITY:	1 INCANDESCENT
LIGHT BEAM MOTION:	FIXED
REFLECTOR INCLOSURE TYPE:	INCLOSED SINGULAR
REFLECTOR SHAPE:	PARABOLIC
SHAPE:	IRREGULAR
OVERALL LENGTH:	5.250 INCHES NOMINAL
OVERALL WIDTH:	9.000 INCHES NOMINAL

Weight and Dimensions

Box Weight	Box Size	Item Weight	Item Dimensions
4.0lbs	--	--	--

National Motor Freight / Schedule B

NMFC	Description	Schedule B
------	-------------	------------

109700

LAMP OR LIGHTING FIXTURES

9405400000 / Electric lamps and lighting
fittings

National Stock Number

FSC	FSG	NIIN	INC
6220	62	00-878-7301 / 008787301	00520

05-91182-56WT7

Indicator Light

INDOOR AND OUTDOOR ELECTRIC LIGHTING FIXTURES NATIONAL STOCK NUMBER 6210-00-935-6908 LIGHT,INDICATOR.

National Stock Number

FSC	FSG	NIIN	INC
6210	62	00-935-6908 / 009356908	00160

8739551

Electric Floodlight

END ITEM IDENTIFICATION:	AUSTIN SHIP CLASS LPD-4 AMPHIBIOUS TRANSPORT DOCKS; TRUCK, CARGO, 5-TON, 6X6, XLWB W/E; CARGO SYSTEM, 463L; ASSAULT AMPHIBIOUS VEHICLE, COMMAND (AAVC-7A1); SHIPBOARD MATERIAL HANDLING EQUIPMENT (MHE); LAV, ANTI-TANK; FAMILY OF MEDIUM TACTICAL VEHICLES-MEDIUM; WASP CLASS LHD; TRUCK, WRECKER, 5-TON (M936)
DEPARTURE FROM CITED DOCUMENT:	AS MODIFIED BY THEADAPTER KIT
FURNISHED ITEMS AND QUANTITY:	1 LAMP
FEATURES PROVIDED:	SWITCH
HAZARDOUS LOCATIONS/ENVIRONMENTAL PROTECTION:	ANY ACCEPTABLE
MATERIAL:	ANY ACCEPTABLE BODY
MOUNTING METHOD:	THREADED STUD
OVERALL DIAMETER:	6.250 INCHES NOMINAL
OVERALL HEIGHT:	11.500 INCHES NOMINAL
LAMP BASE TYPE ACCOMMODATED:	TWO SCREW TERMINALS
LAMP TYPE ACCOMMODATED AND QUANTITY:	1 INCANDESCENT
LIGHT BEAM MOTION:	FIXED
REFLECTOR INCLOSURE TYPE:	INCLOSED SINGULAR
REFLECTOR SHAPE:	PARABOLIC
SHAPE:	IRREGULAR
OVERALL LENGTH:	5.250 INCHES NOMINAL
OVERALL WIDTH:	9.000 INCHES NOMINAL

Weight and Dimensions

Box Weight	Box Size	Item Weight	Item Dimensions
4.0lbs	--	--	--

National Motor Freight / Schedule B

NMFC	Description	Schedule B
------	-------------	------------

109700

LAMP OR LIGHTING FIXTURES

9405400000 / Electric lamps and lighting
fittings

National Stock Number

FSC	FSG	NIIN	INC
6220	62	00-878-7301 / 008787301	00520

200748-0002

Incandescent Lamp

BURNING POSITION:

ANY ACCEPTABLE

Weight and Dimensions

National Stock Number

Box Weight	Box Size	Item Weight	Item Dimensions	FSC	FSG	NIIN	INC
.1lbs	--	--	--	6240	62	01-116-3136 / 011163136	00727

National Motor Freight / Schedule B

NMFC	Description	Schedule B
109550	LAMPS(BULBS) ELEC INCANDESCENT	9405400000 / Electric lamps and lighting fittings

SF26-3131-36

Rf Aircraft M Cable

AIRCRAFT MAINTENANCE AND REPAIR SHOP SPECIALIZED EQUIPMENT NATIONAL STOCK NUMBER 4920-01-565-4273 CABLE,RF,AIRCRAFT,M.

National Stock Number

FSC	FSG	NIIN	INC
4920	49	01-565-4273 / 015654273	77777

2571163

Puller Assembly

TORPEDO MAINTENANCE, REPAIR, AND CHECKOUT SPECIALIZED EQUIPMENT NATIONAL STOCK NUMBER 4921-00-928-6510 PULLER ASSEMBLY.

Weight and Dimensions

National Stock Number

Box Weight	Box Size	Item Weight	Item Dimensions	FSC	FSG	NIIN	INC
38.0lbs	--	--	--	4921	49	00-928-6510 / 009286510	77777

National Motor Freight / Schedule B

NMFC	Description	Schedule B
011760	AIRCRAFT/AIRCRAFT PART VIZ:	9306900080 / Parts for bombs, grenades, torpedos, mines, and similar munitions of war

PWA80574

Interface Devic Adapter Assembly

END ITEM IDENTIFICATION: F117-PW-100 AIRCRAFT ENGINE
SPECIAL FEATURES: WELDED CONSTRUCTION
SUPPLEMENTARY FEATURES: STEEL; 31.000 IN. LG; 3.000 IN. W; 0.750 IN. THK; COMPANY ITEM NAME-ADAPTER, HANDLING, MAIN GEAR BOX

National Stock Number

FSC	FSG	NIIN	INC
4920	49	01-387-2485 / 013872485	51091

GS13262-1

Aircraft Maintenance Fixture

END ITEM IDENTIFICATION: AIRCRAFT PROPELLER CONTROLS
FUNCTIONAL DESCRIPTION: SERVES AS A HOLDING FIXTURE WITH PROTRACTORS FOR MEASURING ROTATIONAL TRAVEL AND BACKLASH
NOMINAL OVERALL HEIGHT: 3.680 INCHES
NOMINAL OVERALL LENGTH: 6.000 INCHES
NOMINAL OVERALL WIDTH: 3.500 INCHES
REFERENCE DATA AND LITERATURE: T.O.'S 3HA2-7-4; 3HA7-3-3
SPECIAL FEATURES: TO NAME: SPEED BIAS TEST FIXTURE

Weight and Dimensions

National Stock Number

Box Weight	Box Size	Item Weight	Item Dimensions	FSC	FSG	NIIN	INC
2.0lbs	73 X 48 X 48	1.8lbs	60 X 38 X 34	4920	49	00-784-1944 / 007841944	37261

National Motor Freight / Schedule B

NMFC	Description	Schedule B
147650	OUTFITS MILITARY EQUIP FOR REPAIR	8466208040 / Jigs and fixtures,nesoi,for machine tools

4920-01-237-2226

Heater Control

END ITEM IDENTIFICATION: F100-PW-100/200/220 ENGINE
FUNCTIONAL DESCRIPTION: USED TO HEAT UP THE VARIOUS PWA HEATERS USED FOR ASSEMBLING ENGINE
REFERENCE DATA AND LITERATURE: SERD NO. 0059; 5333
PART NAME ASSIGNED BY CONTROLLING AGENCY: HEATER CONTROL
SPECIAL FEATURES: C/O CONTROLER,STORAGE CABINET WITH 3 DRAWERS,POWER CABLES; 50 HZ OR 60 HZ WITH A 220 VOLTS POWER SOURCE

National Motor Freight / Schedule B

National Stock Number

NMFC	Description	Schedule B	FSC	FSG	NIIN	INC
061480	CONTROLLERS/PARTS O/T PLASTIC		4920	49	01-237-2226 / 012372226	7777

ALPA1A-D-6+ALPP1-D-3-FA

A Pump Assembly Kit

AIRCRAFT MAINTENANCE AND REPAIR SHOP SPECIALIZED EQUIPMENT NATIONAL STOCK NUMBER 4920-01-572-6602 PUMP ASSEMBLY KIT,A.

Weight and Dimensions

National Stock Number

Box Weight	Box Size	Item Weight	Item Dimensions	FSC	FSG	NIIN	INC
--	--	--	--	4920	49	01-572-6602 / 015726602	7777

AF/M24T-3

Pressurized Cabin Leakage Tester

GENERAL CHARACTERISTICS ITEM DESCRIPTION: C/O A PNEUMATIC WHEEL MOUNTED CHASIS,CABINET ASSY; PRESSURE AND RELIEF VALVES,BLOWER,SMALL AIR COMPRESSOR,CONTROL PANEL AND THE NECESSARY ADAPTERS AND HOSES TO INTERFACE WITH THE AIRCRAFT; AIR SUPPLY SYSTEM,0.0-400.0 CFM AT 2.0-14.5 PSIG; CANOPY AIR SUPPLY,1.0 CFM AT 65.0 PSIG; 220.0-440.0 VAC,3-PHASE,60.0 HZ

ENTRY DATE: 90-04-19

FUNCTIONAL CLASSIFICATION: JJ-7.1

FUNCTIONAL DESCRIPTION: SUPPLIES PRESSURIZED AIR UNDER ANY COMBINATION OF PRESSURES AND FLOWS WITHIN ITS LIMITS FOR CHECKOUT OF ACFT PRESSURIZED CABINS AND CANOPY SEALS

REFERENCE DATA AND LITERATURE: T.O. 33D2-28-12-1,33A4-4-23-1

Weight and Dimensions

National Stock Number

Box Weight	Box Size	Item Weight	Item Dimensions	FSC	FSG	NIIN	INC
400.0lbs		--	--	4920	49	00-601-6926 / 006016926	10937

National Motor Freight / Schedule B

NMFC	Description	Schedule B
133300	MACHINERY/MACHINES SUB 2	

3940-01-311-7665

Hoisting Beam

MATERIAL: STEEL
OVERALL HEIGHT: 3.030 INCHES NOMINAL
OVERALL LENGTH: 11.750 INCHES NOMINAL
OVERALL WIDTH: 1.250 INCHES NOMINAL

Weight and Dimensions

National Stock Number

Box Weight	Box Size	Item Weight	Item Dimensions	FSC	FSG	NIIN	INC
7.8lbs	--	--	--	3940	39	01-311-7665 / 013117665	21771

National Motor Freight / Schedule B

NMFC	Description	Schedule B
104420	BEAMS I/S	

RD-3-12401-0

Tensioner Pulley Assembly

WINCHES, HOISTS, CRANES, AND DERRICKS NATIONAL STOCK NUMBER 3950-01-607-2049 TENSIONER PULLEY ASSEMBLY.

Weight and Dimensions

National Stock Number

Box Weight	Box Size	Item Weight	Item Dimensions	FSC	FSG	NIIN	INC
--		--	--	3950	39	01-607-2049 / 016072049	52049

National Motor Freight / Schedule B

NMFC	Description	Schedule B
117040	CHAIN/PULLEY HOISTS/BLOCKS	

FTG-3-0-3

Plain Cylindrical Plug Gage

SPECIAL
FEATURES:

THE VERIFICATION PIN IS A DOUBLE END GAGE USED TO CHECK THE STARTING HOLE & INSTALLED RETAINER INSIDE DIAMETE. THE STEPPED BLADE END IS USED TO CHECK THE STARTING HOLE FOR SIZE & OVALITY. THE OTHER END IS USED TO VERIFY THE RETAINER'S INSIDE DIAMETER AFTER INSTALLATION. FASTENER SIZE: 3/16 IN; RETAINER SIZE: NOMINAL; CLASS OF FIT: CLASS III

National Stock Number

FSC	FSG	NIIN	INC
5220	52	01-562-0378 / 015620378	15347

715-071-1

Manual Control Lever

END ITEM IDENTIFICATION: W/S CODE BRADLEY; NSN 2350-01-436-0005, ARMORED RECONNAISSANCE AIRBORNE ASSAULT VEHICLE

FEATURES PROVIDED: HANDGRIP

FULCRUM BORE SIZE: 0.128 INCHES NOMINAL

MATERIAL: PLASTIC

MOUNTING METHOD: DRILLED HOLE

OVERALL LENGTH: 2.370 INCHES NOMINAL

OVERALL WIDTH: 0.655 INCHES NOMINAL

PART NAME ASSIGNED BY
CONTROLLING AGENCY: LEVER ASSEMBLY

SPECIAL FEATURES: ASSEMBLY INCLUDES P/N 715-337-2 LEVER, MOLDED, RED PLASTIC AND NSN 5360-01-467-6702, P/N STD405-64 SPRING, COMPRESSION; NEXT HIGHER ASSEMBLY NSN 1005-01-465-9191 GIMBAL ASSEMBLY P/N 12976231, NSN 1090-01-465-8592 GRIP ASSEMBLY, CONTROLER, WEAPON P/N 12976178 AND NSN 1090-01-465-8593 GRIP ASSEMBLY, CONTROLLER, WEAPON P/N 12976179

Weight and Dimensions

National Stock Number

Box Weight	Box Size	Item Weight	Item Dimensions	FSC	FSG	NIIN	INC
.2lbs	--	--	--	3040	30	01-468-5405 / 014685405	61447

National Motor Freight / Schedule B

NMFC	Description	Schedule B
190500	VEHICLE PARTS GROUP	8483909500 / Parts, of bearing housings & plain shaft bearings, housed bearings, clutches, universal joints, flywheels and transmission shafts

1417090

Line Actuating Cylinder Assembly

END ITEM IDENTIFICATION: 4210011379944
COMPRESSED LENGTH: 8.465 INCHES NOMINAL
DESIGN CHARACTERISTICS: SINGLE ACTING SINGLE CYLINDER
EXTENDED LENGTH: 12.047 INCHES NOMINAL

Weight and Dimensions

National Stock Number

Box Weight	Box Size	Item Weight	Item Dimensions	FSC	FSG	NIIN	INC
.6lbs	90 X 10 X 10	--	--	3040	30	01-243-1471 / 012431471	31310

National Motor Freight / Schedule B

NMFC	Description	Schedule B
119260	CYLINDERS:HYDRAULIC/PNEUMATIC	

6505013306252

Usp Dextrose Injection

ACTIVE MEDICAMENT MEDICINAL STRENGTH:	5.000 PERCENTAGE, W/V DEXTROSE ACTIVE INGREDIENT
ADMINISTRATION:	INTRAVENOUS
PART NAME ASSIGNED BY CONTROLLING AGENCY:	DEXTROSE INJECTION USP 5% 1000ML BAG 12S
PRIMARY CONTAINER CONTENT QUANTITY:	1000.000 MILLILITERS
PRIMARY CONTAINER TYPE:	BAG, PLASTIC
SPECIAL FEATURES:	FOR THE MMESO STANDARDIZED JOINT PRODUCT OF CHOICE, USE CAGE 11171, AND PART NUMBER L5100, NDC00264-7510-00
TOTAL PRIMARY CONTAINER QUANTITY:	12

Weight and Dimensions

National Stock Number

Box Weight	Box Size	Item Weight	Item Dimensions	FSC	FSG	NIIN	INC
1.0lbs	1 X 1 X 1	--	--	6505	65	01-330-6252 / 013306252	09068

National Motor Freight / Schedule B

NMFC	Description	Schedule B
058770	DRUGS/MEDICINES/VITAMINS	3004909170 / Medicaments primarily affecting electrolytic, caloric or water balance, put up in meas doses or in forms or pkg for retail sale, not elswhr spec/incl

LS-600-61

Individual First Aid Kit

DOCUMENT SOURCE: 89875
 DOCUMENT TYPE: FEDERAL SUPPLY CATALOG
 COMPONENT: GOVERNMENT
 DOCUMENT ORIGIN:
 PART NAME ASSIGNED:
 BY CONTROLLING AGENCY: FIRST AID KIT INDIVIDUAL
 SPECIAL FEATURES: DOCUMENT IDENTIFICATION:C-6545-IL, VOL 2
 SUPPLY ITEMS AND QUANTITIES: PACKED IN 6545-01-094-6142 CASE MED INSTR AND SUPPLY SET; C/O 6505-00-914-3593 POVIDONE-IODINE,TOPICAL SOLUTION,USP-1/50 BX; 6508-01-265-0079 LIPSTICK ANTICHAP-1/100 PG; 6510-00-159-4883 DRESSING FIRST AID FIELD-2 EA; 6510-00-200-3180 BANDAGE GAUZE-1 EA; 6510-00-201-1755 BANDAGE MUSLIN-1 EA; 6510-00-913-7909 BANDAGE ADHESIVE-18/300 BX; 6545-00-853-6309 FIRST AID KIT EYE DRESSING-1 EA; 6545-01-094-6136 INSERT FIRST AID KIT CASE-1 EA; 6850-00-985-7166 WATER PURIFICATION TABLET 50S-1 BT; 6530-01-365-2081 BOTTLE,SAFETY CAP-2/400 PG; 6530-00-042-8416 BOTTLE SAFETY CAP 200S MAY BE SUBSTITUTED UNTIL STOCKS ARE DEPLETED

National Motor Freight / Schedule B

National Stock Number

NMFC	Description	Schedule B	FSC	FSG	NIIN	INC
108107	KITS,EMERGENCY	9018908000 / Other instruments and appliances used in medical, surgical, dental or veterinary sciences	6545	65	01-094-8412 / 010948412	23705

9905-01-374-0882

Distance-to-go Marker Set

FURNISHED ITEMS: 22 EA, SIGN STANDS; 22 EA, SIGN STAND STORAGE BAGS; 2 EA, 48 INCH SIGNS NUMBERS 1-9; 4 EA, 48 INCH SIGNS BARRIER SYMBOL(DISC); 22 EA, 48 INCH CROSSBRACE; 11 EA, SIGN STORAGE BAGS

SPECIAL FEATURES: DISTANCE-TO-GO MARKER SET; EACH STORAGE BAG HOLDS TWO SIGNS ROLLED UP ON THE CROSS BRACE AND MARKED WITH SIGN LEGEND; SET IS PACKED AND SHIPPED IN A WOODEN CRATE

National Stock Number

FSC	FSG	NIIN	INC
9905	99	01-374-0882 / 013740882	7777

12496358

Rubber Strip

END ITEM IDENTIFICATION:

3990-01-442-1941

MATERIAL:

RUBBER

PART NAME ASSIGNED BY CONTROLLING AGENCY:

BACK STRIP

Weight and Dimensions

National Stock Number

Box Weight	Box Size	Item Weight	Item Dimensions	FSC	FSG	NIIN	INC
--		--	--	9320	93	01-615-1509 / 016151509	25879

National Motor Freight / Schedule B

NMFC	Description	Schedule B
194120	WASHERS/GASKETS/PCKG DVCS	

VS80574

Nonmetallic Special Shaped Secti

MISCELLANEOUS FABRICATED NONMETALLIC MATERIALS NATIONAL STOCK NUMBER 9390-01-106-2282 NONMETALLIC SPECIAL SHAPED SECTI.

Weight and Dimensions

National Stock Number

Box Weight	Box Size	Item Weight	Item Dimensions	FSC	FSG	NIIN	INC
.5lbs	--	--	--	9390	93	01-106-2282 / 011062282	30219

National Motor Freight / Schedule B

NMFC	Description	Schedule B
156600	PLASTIC/RUBBER ARTICLE VIZ:	

9390-00-146-1607

Nonmetallic Special Shaped Secti

APERTURE HEIGHT:	0.510 INCHES NOMINAL
BASE FLANGE THICKNESS:	0.120 INCHES NOMINAL
MINIMUM TENSILE STRENGTH:	1000 POUNDS PER SQUARE INCH
NONMETALLIC HARDNESS RATING:	45.0 MINIMUM SHORE DUROMETER A AND 55.0 MAXIMUM SHORE DUROMETER A
OUTSIDE RADIUS:	0.280 INCHES NOMINAL
OVERALL HEIGHT:	0.750 INCHES NOMINAL
INSIDE RADIUS:	0.160 INCHES NOMINAL
LENGTH:	120.000 INCHES MAXIMUM
OVERALL WIDTH:	1.160 INCHES NOMINAL
SPECIAL FEATURES:	COLOR,BLACK,MATT: RUBBER, STM23-402, CLASS 1, GRADE 50, LOCKHEED AIRCRAFT CORP
TEMP RATING:	-65.0 DEG FAHRENHEIT AND 400.0 DEG FAHRENHEIT

Weight and Dimensions

National Stock Number

Box Weight	Box Size	Item Weight	Item Dimensions	FSC	FSG	NIIN	INC
1.4lbs	--	--	--	9390	93	00-146-1607 / 001461607	30219

National Motor Freight / Schedule B

NMFC	Description	Schedule B
156600	PLASTIC/RUBBER ARTICLE VIZ:	

LS7074-1

Nonmetallic Special Shaped Secti

MISCELLANEOUS FABRICATED NONMETALLIC MATERIALS NATIONAL STOCK NUMBER 9390-01-381-8687 NONMETALLIC SPECIAL SHAPED SECTI.

National Stock Number

FSC	FSG	NIIN	INC
9390	93	01-381-8687 / 013818687	30219

13009771

Pin Alignment Tool

END ITEM IDENTIFICATION: MULTIPURPOSE INDIVIDUAL MUNITION/SHORT RANGE ASSAULT WEAPON (MPIM/SRAW) SURFACE TO SURFACE MISSILE SYSTEM

Weight and Dimensions

National Stock Number

Box Weight	Box Size	Item Weight	Item Dimensions	FSC	FSG	NIIN	INC
.1lbs	--	--	--	1450	14	01-437-9670 / 014379670	7777

National Motor Freight / Schedule B

NMFC	Description	Schedule B
064300	EXPLOSIVES:AMMO OR CARTRIDGES	9306900060 / Parts for guided missiles

MIL-R-3065 SC515

Rubber Pad

GENERAL CHARACTERISTICS ITEM DESCRIPTION:

NEOPRENE RUBBER,TYPE S,CLASS SC,GRADE 515,SUFFIX C,F,Z,SPEC MIL-R-3065

Weight and Dimensions

National Stock Number

Box Weight	Box Size	Item Weight	Item Dimensions	FSC	FSG	NIIN	INC
.1lbs	--	--	--	1430	14	01-191-8702 / 011918702	7777

National Motor Freight / Schedule B

NMFC	Description	Schedule B
156600	PLASTIC/RUBBER ARTICLE VIZ:	8529104000 / Antennas & parts for radar, radio navigational aids and radio remote controls

78011-211-1

Tube To Hose Straight Adapter

CONNECTION STYLE:	GASKET SEAL (TUBE) 1ST END
CONNECTION TYPE:	THREADED INTERNAL TUBE 1ST END
CONNECTION TYPE:	UNTHREADED INTERNAL HOSE 2ND END
NOMINAL OUTSIDE DIAMETER HOSE ACCOMMODATED:	3.000 INCHES 2ND END
NOMINAL OVERALL LENGTH:	6.000 INCHES
NOMINAL THREAD SIZE:	1.250 INCHES 1ST END
THREAD CLASS:	3B 1ST END
THREAD SERIES DESIGNATOR:	UNF 1ST END

Weight and Dimensions

National Stock Number

Box Weight	Box Size	Item Weight	Item Dimensions	FSC	FSG	NIIN	INC
.7lbs	80 X 50 X 50	--	--	4730	47	01-389-6438 / 013896438	03777

National Motor Freight / Schedule B

NMFC	Description	Schedule B
136500	METAL/METAL ALLOYS SUB1	

79003-16-0043

Metallic Hose Assembly

PART NAME ASSIGNED BY CONTROLLING AGENCY:

TUBE ASSEMBLY, METAL

Weight and Dimensions

National Stock Number

Box Weight	Box Size	Item Weight	Item Dimensions	FSC	FSG	NIIN	INC
--	--	--	--	4720	47	01-594-8317 / 015948317	17972

VHN20-20MJF

Quick Disconnect Coupling Half

CONNECTION STYLE:	PLAIN ALL ENDS
CONNECTION TYPE:	EXTERNAL QUICK DISCONNECT ALL ENDS
CONNECTION TYPE:	THREADED EXTERNAL PIPE FIRST FLUID END CONNECTION
FEATURES PROVIDED:	SELF-SEALING
MATERIAL DOCUMENT AND CLASSIFICATION:	QQ-S-637 FED SPEC SINGLE MATERIAL RESPONSE BODY
MATERIAL:	STEEL BODY
MATING END IDENTIFICATION:	EDGEWOOD ARSENAL,COUPLING HALF,QUICK DISCONNECT,PART NO. D150-1-12-12
NOMINAL THREAD SIZE:	1.250 INCHES ALL ENDS
NONDEFINITIVE SPEC/STD DATA:	2 TYPE
LEG LENGTH:	1.312 INCHES NOMINAL
QUICK DISCONNECT METHOD:	PUSH-PULL ALL ENDS
OVERALL LENGTH:	3.468 INCHES NOMINAL
STYLE DESIGNATOR:	MALE COUPLING HALF
THREAD SERIES DESIGNATOR:	NPTF ALL ENDS

Weight and Dimensions

National Stock Number

Box Weight	Box Size	Item Weight	Item Dimensions	FSC	FSG	NIIN	INC
1.2lbs	--	--	--	4730	47	01-037-4931 / 010374931	18681

National Motor Freight / Schedule B

NMFC	Description	Schedule B
052190	PIPE,TUBING,OR PIPE OR TUBING FITTI	7307199030 / Unions, pipe, of iron or steel, cast

12340337

Weapon Station Tube Assembly

END ITEM IDENTIFICATION: TRUCK 1-1/4 TON,PCCN CHMMWV
CONSISTING OF 5 EACH SPACER,P/N 5584702,FSCM 34623; 5 EACH SPACER,P/N 5583626,FSCM 34623; 1 EACH TUBE WEAPON STATION-LEFT,P/N 5584795-C,FSCM 34623; 1 EACH TUBE WEAPON STATION-CENTER,P/N 5584794-D,FSCM 34623; 1 EACH TUBE WEAPON STATION-FRONT,P/N 5584796-C,FSCM 34623; 1 EACH TUBE WEAPON STATION-REAR,P/N 5584797-C,FSCM 34623; 1 EACH REINFORCEMENT TUBE ASSEMBLY,P/N 5584701-R,FSCM 34623; 10 EACH HOLES 1.500 INS DIA

Weight and Dimensions

National Stock Number

Box Weight	Box Size	Item Weight	Item Dimensions	FSC	FSG	NIIN	INC
10.0lbs	--	--	--	4710	47	01-189-9727 / 011899727	77777

National Motor Freight / Schedule B

NMFC	Description	Schedule B
133300	MACHINERY/MACHINES	

4720-00-528-2945

Nonmetallic Hose Assembly

END CONNECTION DESIGN:	STRAIGHT 1ST END
END CONNECTION DESIGN:	STRAIGHT 2ND END
BURST TEST PRESSURE:	500.0 POUNDS PER SQUARE INCH
CONNECTION STYLE:	CAM OR LEVER (EXTERNAL) 2ND END
CONNECTION STYLE:	CAM OR LEVER (INTERNAL) 1ST END
CONNECTION TYPE:	EXTERNAL QUICK DISCONNECT 2ND END
CONNECTION TYPE:	INTERNAL QUICK DISCONNECT 1ST END
CROSS-SECTIONAL SHAPE STYLE:	ROUND
FEATURES PROVIDED:	ELECTROSTATIC DISCHARGE CAPABILITY
HYDROSTATIC TEST PRESSURE:	150.0 POUNDS PER SQUARE INCH
MEASURING METHOD AND LENGTH:	120.000 INCHES NOMINAL EXCLUDING END FITTINGS
NONDEFINITIVE SPEC/STD DATA:	1 CLASS AND 5 SIZE AND B STYLE AND 1 TYPE
OUTER COVERING ENVIRONMENTAL PROTECTION:	FUEL RESISTANT AND OIL RESISTANT AND MILDEW RESISTANT AND OZONE RESISTANT
OUTSIDE DIAMETER:	2.125 INCHES NOMINAL
INSIDE DIAMETER:	1.500 INCHES NOMINAL
INSIDE SURFACE CONDITION:	SMOOTH
LAYER COMPOSITION AND LOCATION:	OUTER LAYER RUBBER IMPREGNATED BRAIDED RAYON CORD AND 1ST LAYER BRAIDED COTTON CORD

Weight and Dimensions

National Stock Number

Box Weight	Box Size	Item Weight	Item Dimensions	FSC	FSG	NIIN	INC
13.0lbs		--	--	4720	47	00-528-2945 / 005282945	20311

National Motor Freight / Schedule B

NMFC	Description	Schedule B
051140	HOSE:NOI TUBING	

4720-00-930-5974

Air Duct Hose Assembly

END ITEM IDENTIFICATION:	GRUMMAN A10 AIRCRAFT
CONNECTION TYPE:	COUPLING FIRST END
CONNECTION TYPE:	COUPLING SECOND END
COUPLING LOCKING DEVICE QUANTITY:	3 FIRST END
COUPLING LOCKING DEVICE QUANTITY:	3 SECOND END
COUPLING STYLE:	TWIST-LOCK W/INTERNAL LOCKING CAMS SECOND END
COUPLING STYLE:	TWIST-LOCK W/LOCKING OPENINGS FIRST END
CROSS-SECTIONAL SHAPE STYLE:	ROUND
FEATURES PROVIDED:	OZONE RESISTANT AND SCUFF STRIP AND STOWAGE DEVICE
MEASURING METHOD AND LENGTH:	180.000 INCHES NOMINAL OVERALL
NONDEFINITIVE SPEC/STD DATA:	A SIZE
INSIDE DIAMETER:	12.000 INCHES NOMINAL FIRST END
SPECIAL FEATURES:	FOREST GREEN COLOR
STYLE DESIGNATOR:	HELICALLY WOUND CONTINUOUS WIRE SUPPORTED

Weight and Dimensions

National Stock Number

Box Weight	Box Size	Item Weight	Item Dimensions	FSC	FSG	NIIN	INC
22.0lbs	130 X 130 X 220	--	--	4720	47	00-930-5974 / 009305974	18451

National Motor Freight / Schedule B

NMFC	Description	Schedule B
051035	DUCTS:AIR SYSTEM	8415909000 / Parts, of air conditioning machines

4960

Nonmetallic Hose Assembly

END CONNECTION DESIGN:	STRAIGHT 1ST END
END CONNECTION DESIGN:	STRAIGHT 2ND END
END ITEM IDENTIFICATION:	F/A-18 HORNET AIRCRAFT
BURST TEST PRESSURE:	5000.0 POUNDS PER SQUARE INCH
CONNECTION STYLE:	INVERTED FLARE 1ST END
CONNECTION STYLE:	INVERTED FLARE 2ND END
CONNECTION TYPE:	THREADED EXTERNAL TUBE 1ST END
CONNECTION TYPE:	THREADED INTERNAL AND EXTERNAL TUBE 2ND END
CRITICALITY CODE JUSTIFICATION:	FEAT
CROSS-SECTIONAL SHAPE STYLE:	ROUND
EXTERIOR COLOR:	BLACK
HYDROSTATIC TEST PRESSURE:	1400.0 POUNDS PER SQUARE INCH
MEASURING METHOD AND LENGTH:	25.219 INCHES MINIMUM OVERALL AND 25.469 INCHES MAXIMUM OVERALL
MEDIA FOR WHICH DESIGNED:	FUEL/OIL, HYDROCARBON SINGLE RESPONSE
NOMINAL THREAD SIZE:	0.438 INCHES AND 0.625 INCHES 2ND END
NOMINAL THREAD SIZE:	0.438 INCHES 1ST END
OUTSIDE DIAMETER:	0.469 INCHES MINIMUM AND 0.500 INCHES MAXIMUM

Weight and Dimensions

National Stock Number

Box Weight	Box Size	Item Weight	Item Dimensions	FSC	FSG	NIIN	INC
.1lbs	100 X 40 X 10	--	--	4720	47	00-580-7470 / 005807470	20311

National Motor Freight / Schedule B

NMFC	Description	Schedule B
051140	HOSE:NOI TUBING	

M6000-A-00600

Nonmetallic Hose

BURST TEST PRESSURE:	1000.0 POUNDS PER SQUARE INCH SINGLE RESPONSE
CROSS-SECTIONAL SHAPE STYLE:	ROUND
HYDROSTATIC TEST PRESSURE:	500.0 POUNDS PER SQUARE INCH SINGLE RESPONSE
MATERIAL:	RUBBER SYNTHETIC TUBE
MEDIA FOR WHICH DESIGNED:	ALCOHOL, ETHYL SINGLE RESPONSE AND ETHYLENE GLYCOL SINGLE RESPONSE AND FUEL/OIL, HYDROCARBON SINGLE RESPONSE AND WATER SINGLE RESPONSE
MEASURING METHOD AND LENGTH:	72.000 INCHES NOMINAL OVERALL
OUTSIDE DIAMETER:	0.562 INCHES MINIMUM AND 0.625 INCHES MAXIMUM
INSIDE DIAMETER:	0.250 INCHES NOMINAL
INSIDE SURFACE CONDITION:	SMOOTH
LAYER COMPOSITION AND LOCATION:	1ST LAYER BRAIDED TEXTILE YARN ERR-100
LAYER COMPOSITION AND LOCATION:	OUTER LAYER MOLDED RUBBER, CHLOROPRENE ERR-100
SPECIFICATION/STANDARD DATA:	81349-MIL-H-6000 GOVERNMENT SPECIFICATION
TEMP RATING:	-40.0 DEG FAHRENHEIT SINGLE RESPONSE AND 300.0 DEG FAHRENHEIT SINGLE RESPONSE

Weight and Dimensions

National Stock Number

Box Weight	Box Size	Item Weight	Item Dimensions	FSC	FSG	NIIN	INC
--	--	--	--	4720	47	01-267-0367 / 012670367	22670

National Motor Freight / Schedule B

NMFC	Description	Schedule B
051140	HOSE:NOI TUBING	

49B6568-1

Nonmetallic Hose Assembly

END CONNECTION DESIGN:	STRAIGHT 1ST END
BURST TEST PRESSURE:	16000.0 POUNDS PER SQUARE INCH
CONNECTION STYLE:	PLAIN 1ST END
CONNECTION TYPE:	THREADED EXTERNAL PIPE 1ST END
CROSS-SECTIONAL SHAPE STYLE:	ROUND
HYDROSTATIC TEST PRESSURE:	8000.0 POUNDS PER SQUARE INCH
MAXIMUM OPERATING PRESSURE:	4000.0 POUNDS PER SQUARE INCH
MEASURING METHOD AND LENGTH:	120.000 INCHES NOMINAL OVERALL
MEDIA FOR WHICH DESIGNED:	FUEL/OIL, HYDROCARBON SINGLE RESPONSE
MINIMUM INSIDE BENDING RADIUS:	5.000 INCHES
NOMINAL THREAD SIZE:	0.375 INCHES 1ST END
OUTSIDE DIAMETER:	0.812 INCHES NOMINAL
INSIDE DIAMETER:	0.375 INCHES NOMINAL
INSIDE SURFACE CONDITION:	SMOOTH
LAYER COMPOSITION AND LOCATION:	2ND LAYER BRAIDED STEEL WIRE AND OUTER LAYER MOLDED RUBBER, SYNTHETIC AND 1ST LAYER BRAIDED STEEL WIRE
THREAD DIRECTION:	RIGHT-HAND 1ST END
THREAD SERIES DESIGNATOR:	NPT 1ST END

Weight and Dimensions

National Stock Number

Box Weight	Box Size	Item Weight	Item Dimensions	FSC	FSG	NIIN	INC
6.5lbs	220 X 220 X 40	--	--	4720	47	00-241-7660 / 002417660	20311

National Motor Freight / Schedule B

NMFC	Description	Schedule B
051140	HOSE:NOI TUBING	

R44150P06

Connector Dynatube Fitting

GENERAL CHARACTERISTICS ITEM DESCRIPTION:

STEEL (17-4PH),1.384 IN. LG

Weight and Dimensions

National Stock Number

Box Weight	Box Size	Item Weight	Item Dimensions	FSC	FSG	NIIN	INC
.1lbs	--	--	--	4730	47	01-034-4641 / 010344641	7777

National Motor Freight / Schedule B

NMFC	Description	Schedule B
095190	HARDWARE,	

NV23412-12A

Quick Disconnect Coupling Half

END ITEM IDENTIFICATION:

C-17A AIRCRAFT

Weight and Dimensions

National Stock Number

Box Weight	Box Size	Item Weight	Item Dimensions	FSC	FSG	NIIN	INC
--		--	--	4730	47	01-418-2026 / 014182026	18681

AE99115G

Quick Disconnect Coupling Half

CONNECTION STYLE:	FLARELESS ALL ENDS
CONNECTION TYPE:	THREADED EXTERNAL TUBE FIRST FLUID END CONNECTION
MATERIAL:	STEEL CORROSION RESISTING BODY
NOMINAL OUTSIDE DIAMETER TUBE ACCOMMODATED:	0.375 INCHES ALL ENDS
NOMINAL THREAD SIZE:	0.562 INCHES ALL ENDS
LEG LENGTH:	0.469 INCHES NOMINAL
QUICK DISCONNECT METHOD:	TWIST-LOCK ALL ENDS
SEAT ANGLE:	12.0 DEGREES
OVERALL LENGTH:	1.764 INCHES NOMINAL
STYLE DESIGNATOR:	MALE COUPLING HALF
THREAD CLASS:	3A ALL ENDS
THREAD SERIES DESIGNATOR:	UNJF ALL ENDS

Weight and Dimensions

National Stock Number

Box Weight	Box Size	Item Weight	Item Dimensions	FSC	FSG	NIIN	INC
.3lbs		--	--	4730	47	01-255-5341 / 012555341	18681

National Motor Freight / Schedule B

NMFC	Description	Schedule B
052190	PIPE,TUBING,OR PIPE OR TUBING FITTI	7307290000 / Stainless steel tube or pipe fittings nesoi

LCD26004BR

Quick Disconnect Coupling Half

END ITEM IDENTIFICATION:

LAV-25 SLEP 2320-01-123-1602

Weight and Dimensions

National Stock Number

Box Weight	Box Size	Item Weight	Item Dimensions	FSC	FSG	NIIN	INC
.1lbs	--	--	--	4730	47	01-495-7482 / 014957482	18681

National Motor Freight / Schedule B

NMFC	Description	Schedule B
051420	CONDUITS,O/T EARTHEN:PIPE FITTINGS	

SM-C-318484-1

Waste Drain Stopper

END ITEM IDENTIFICATION: 5411-00-999-4935 NONEXPANDABLE SHELTER
DIAMETER: 1.125 INCHES
MATERIAL: RUBBER AND STEEL
SPECIAL FEATURES: FURNISHED W/BRASS CHAIN
UNIT TYPE: PLUG

Weight and Dimensions

National Stock Number

Box Weight	Box Size	Item Weight	Item Dimensions	FSC	FSG	NIIN	INC
.1lbs	--	--	--	4510	45	00-121-6096 / 001216096	07109

National Motor Freight / Schedule B

NMFC	Description	Schedule B
159450	STOPPERS(PLUGS)BASIN LAV/TUB	

934U01000BA-D3T5

Electric Space Heater

END ITEM IDENTIFICATION:	5411-01-506-1774
AIR CIRCULATION DEVICE:	PROPELLER FAN
CURRENT TYPE:	AC
DEPTH:	3.000 INCHES NOMINAL
FREQUENCY IN HERTZ:	60.0
HEAT DISCHARGE OUTLET TYPE:	STATIONARY
HEAT MEDIUM TYPE:	AIR
HEAT OUTLET QUANTITY:	1
HEATING ELEMENT TYPE:	ELECTRIC NONIMMERSION
HEAT DELIVERY DIRECTION:	HORIZONTAL
HEIGHT:	12.000 INCHES NOMINAL
MOUNTING TYPE:	WALL SUSPENDED, ROOM EXTERIOR, THROUGH WALL
OPERATING CONTROL TYPE:	THERMOSTATIC
QUANTITY:	1
PHASE:	SINGLE
PRIME MOVER TYPE:	ELECTRIC MOTOR
SPECIAL FEATURES:	RATED AT 1000 WATTS

Weight and Dimensions

Box Weight	Box Size	Item Weight	Item Dimensions
------------	----------	-------------	-----------------

-- -- -- --

National Motor Freight / Schedule B

National Stock Number

NMFC	Description	Schedule B	FSC	FSG	NIIN	INC
062220	HEATER, PORTABLE	8516290000 / Electric space heating apparatus & electric soil heating apparatus	4520	45	01-530-6352 / 015306352	03232

4320-01-443-9094

Spring Loade Shaft Seal Assembly

SPECIAL FEATURES: MECHANICAL SEAL FOR THIS UNIT IS TO BE ONE OF THE FOLLOWING, CRANE TYPE 1, SIZE 7/8 PER F - SD-3000 FEG A CODE BF (50) 1D1 (316)

Weight and Dimensions

National Stock Number

Box Weight	Box Size	Item Weight	Item Dimensions	FSC	FSG	NIIN	INC
--	--	--	--	4320	43	01-443-9094 / 014439094	32556

National Motor Freight / Schedule B

NMFC	Description	Schedule B
128000	PUMPS PWR/WORKING HEADS/PARTS	8413919520 / Parts, of pumps for liquids

29-119HP5 (FP10-6657)

Fluid Filter Element

CENTRIFUGALS, SEPARATORS, AND PRESSURE AND VACUUM FILTERS NATIONAL STOCK NUMBER 4330-01-046-6961 FILTER ELEMENT,FLUID.

Weight and Dimensions

National Stock Number

Box Weight	Box Size	Item Weight	Item Dimensions	FSC	FSG	NIIN	INC
1.4lbs	--	--	--	4330	43	01-046-6961 / 010466961	32624

National Motor Freight / Schedule B

NMFC	Description	Schedule B
069100	FILTERS:CARTRIDGES/ELEMENTS	8421290065 / Filtering or purifying machinery and apparatus for liquids, nesoi

18/6-6/30/PPG/3HR/.875 x .188/A

Axial Fan Impeller

ATTACHMENT METHOD:

KEYWAY

BLADE QUANTITY:

6

DIAMETER:

18.000 INCHES NOMINAL

HUB LOCATION:

CENTER

MATERIAL:

PLASTIC POLYPROPYLENE BLADE

ROTATION DIRECTION FOR WHICH DESIGNED:

CLOCKWISE

STYLE DESIGNATOR:

STRAIGHT TIP

National Stock Number

FSC	FSG	NIIN	INC
4140	41	01-475-4270 / 014754270	10087

9454132

Air Conditioning Filter Element

END ITEM IDENTIFICATION:

NSN4120014490459, AIR CONDITIONER

STYLE DESIGNATOR:

ROUND (BASICALLY FLAT)

Weight and Dimensions

National Stock Number

Box Weight	Box Size	Item Weight	Item Dimensions	FSC	FSG	NIIN	INC
.1lbs	--	--	--	4130	41	01-493-9621 / 014939621	06458

National Motor Freight / Schedule B

NMFC	Description	Schedule B
053180	REFRIGERATORS OR FREEZERS	8415909000 / Parts, of air conditioning machines

1559AS250-1 Rev. D

Axial Fan Impeller

FANS, AIR CIRCULATORS, AND BLOWER EQUIPMENT NATIONAL STOCK NUMBER 4140-01-142-1213 IMPELLER,FAN,AXIAL.

Weight and Dimensions

National Stock Number

Box Weight	Box Size	Item Weight	Item Dimensions	FSC	FSG	NIIN	INC
2.1lbs	--	--	--	4140	41	01-142-1213 / 011421213	10087

National Motor Freight / Schedule B

NMFC	Description	Schedule B
162813	PROJECTILE/RCKT PTS PLSTC/RUBR	8414901040 / Parts of fans (including blowers) and ventilating or recycling hoods for permanent installation (of subheading 8414.51.00)

PS70087-2

Shackle

END CONDITION:	THREADED
CLOSURE HEAD STYLE:	HEXAGON
EYELET STYLE:	ROUND PLAIN
MATERIAL:	STEEL COMP 4130 OR STEEL COMP 4140
OPENING WIDTH:	2.313 INCHES MINIMUM AND 2.437 INCHES MAXIMUM
INSIDE LENGTH:	4.625 INCHES MINIMUM AND 4.875 INCHES MAXIMUM
MATERIAL DIAMETER:	0.750 INCHES NOMINAL
MATERIAL DOCUMENT AND CLASSIFICATION:	FED-STD-66 FED STD SINGLE MATERIAL RESPONSE
SPECIAL FEATURES:	PROOF LOAD 20000 LBS,SCREW CAP MS90727-197,NUT MS35691-61
STYLE DESIGNATOR:	ANCHOR
SURFACE TREATMENT DOCUMENT AND CLASSIFICATION:	MIL-P-16232 TY 2 CL 4B MIL SPEC SINGLE TREATMENT RESPONSE AND MIL-W-3688 MIL SPEC SINGLE TREATMENT RESPONSE
SURFACE TREATMENT:	PHOSPHATE

Weight and Dimensions

National Stock Number

Box Weight	Box Size	Item Weight	Item Dimensions	FSC	FSG	NIIN	INC
3.1lbs	73 X 65 X 23	3.5lbs	69 X 61 X 20	4030	40	00-678-8562 / 006788562	11074

National Motor Freight / Schedule B

NMFC	Description	Schedule B
105200	FITTINGS CABLE/CHAIN/ROPE I/S	

PS70087-2

Shackle

END CONDITION:	THREADED
CLOSURE HEAD STYLE:	HEXAGON
EYELET STYLE:	ROUND PLAIN
MATERIAL:	STEEL COMP 4130 OR STEEL COMP 4140
OPENING WIDTH:	2.313 INCHES MINIMUM AND 2.437 INCHES MAXIMUM
INSIDE LENGTH:	4.625 INCHES MINIMUM AND 4.875 INCHES MAXIMUM
MATERIAL DIAMETER:	0.750 INCHES NOMINAL
MATERIAL DOCUMENT AND CLASSIFICATION:	FED-STD-66 FED STD SINGLE MATERIAL RESPONSE
SPECIAL FEATURES:	PROOF LOAD 20000 LBS,SCREW CAP MS90727-197,NUT MS35691-61
STYLE DESIGNATOR:	ANCHOR
SURFACE TREATMENT DOCUMENT AND CLASSIFICATION:	MIL-P-16232 TY 2 CL 4B MIL SPEC SINGLE TREATMENT RESPONSE AND MIL-W-3688 MIL SPEC SINGLE TREATMENT RESPONSE
SURFACE TREATMENT:	PHOSPHATE

Weight and Dimensions

National Stock Number

Box Weight	Box Size	Item Weight	Item Dimensions	FSC	FSG	NIIN	INC
3.1lbs	73 X 65 X 23	3.5lbs	69 X 61 X 20	4030	40	00-678-8562 / 006788562	11074

National Motor Freight / Schedule B

NMFC	Description	Schedule B
105200	FITTINGS CABLE/CHAIN/ROPE I/S	

4010-01-225-9838

Messenger Assembly

CHAIN AND WIRE ROPE NATIONAL STOCK NUMBER 4010-01-225-9838 MESSENGER ASSEMBLY.

Weight and Dimensions

National Stock Number

Box Weight	Box Size	Item Weight	Item Dimensions	FSC	FSG	NIIN	INC
165.0lbs	--	--	--	4010	40	01-225-9838 / 012259838	77777

National Motor Freight / Schedule B

NMFC	Description	Schedule B
136500	METAL/METAL ALLOYS	

GA5000

Climbing Safety Sleeve

GENERAL CHARACTERISTICS ITEM DESCRIPTION: ALUMINUM,STEEL,11.000 IN. H,3.000 IN. W,5.000 IN. DP,STATIC LOAD RATING 1000 POUNDS MAX; USED ON NOTCHED RAILS ONLY

Weight and Dimensions

National Stock Number

Box Weight	Box Size	Item Weight	Item Dimensions	FSC	FSG	NIIN	INC
4.1lbs	--	--	--	4240	42	01-042-9688 / 010429688	7777

National Motor Freight / Schedule B

NMFC	Description	Schedule B
106940	SPACERS/SEPARATORS I/S TUBULAR	

5959318 PC 8

Fire Blanket

BASIC MATERIAL:	GLASS FIBER
BINDING METHOD:	STITCH
BLENDED MATERIAL:	NOT INCLUDED
FSC APPLICATION DATA:	FIRE FIGHTING EQUIPMENT
LENGTH:	174.000 INCHES NOMINAL
WIDTH:	180.000 INCHES NOMINAL

Weight and Dimensions

National Stock Number

Box Weight	Box Size	Item Weight	Item Dimensions	FSC	FSG	NIIN	INC
14.0lbs	200 X 180 X 30	--	--	4210	42	01-306-7827 / 013067827	06349

National Motor Freight / Schedule B

NMFC	Description	Schedule B
136500	METAL/METAL ALLOYS	

M331/M201

Rain Erosion Resisti Coating Kit

APPLICATION METHOD:	BRUSHING AS PACKAGED OR SPRAYING AS IS
BASIC FORMULATION TYPE:	POLYURETHANE
COLORING METHOD:	PIGMENTED
COLOR:	BLACK
CONTENT WITHIN EACH UNIT PACKAGE:	CONSISTS OF COMPONENT A (PIGMENTED POLYURETHANE RESIN) AND COMPONENT B (CURING AGENT) TO EQUAL 1 GALLON
ENVIRONMENTAL ATTRIBUTE CODE:	LOW VOLATILE ORGANIC COMPOUND - COATINGS - AEROSPACE OPERATIONS COATINGS
FEATURES PROVIDED:	LEAD FREE
GLOSS DESIGNATION:	GLOSS
QUANTITY WITHIN EACH UNIT PACKAGE:	1.000 GALLONS
SPECIAL FEATURES:	FOR AIRCRAFT RADOMES AND LEADING EDGES
STORAGE TYPE:	TEMPERATURE CONTROLLED WAREHOUSE
VOLATILE ORGANIC COMPOUND IN GRAMS PER LITER:	420.0

Weight and Dimensions

National Stock Number

Box Weight	Box Size	Item Weight	Item Dimensions	FSC	FSG	NIIN	INC
--	--	--	--	8010	80	01-054-7229 / 010547229	20631

National Motor Freight / Schedule B

NMFC	Description	Schedule B
149980	PAINT AND RELATED MATERIALS	3208900000 / Paints and varnishes(incl enamels & lacquers)based on synthetic polymers,etc in a nonaqueous medium,nesoi

8030-01-476-2407

Sealing Compound

COLOR: BLACK
FEATURES PROVIDED: SEPARATE CATALYST
MATERIAL: RUBBER SYNTHETIC
QUANTITY WITHIN EACH UNIT PACKAGE: 3.500 OUNCES
RATED DRYING TIME: 5.000 HOURS MAXIMUM
PHYSICAL FORM: PASTE
SPECIAL FEATURES: NICKEL FILLED; ELECTRICALLY CONDUCTIVE; SERVICE TEMPERATURE RANGE OF MINUS 67 DEG F TO PLUS 250 DEG F, INTERMITTENT USE TO 360 DEG F; POLYTHIOETHER; 1 HOUR WORKING TIME
SPECIFIC USAGE DESIGN: CORROSION PROTECTION FOR ALUMINUM ALLOYS AND BETWEEN DISSIMILAR METALS; ALSO FOR EMI/RFI SHIELDING
SUPPLEMENTARY FEATURES: 3-1/2 OUNCE IN 6 OUNCE CARTRIDGE

Weight and Dimensions

National Stock Number

Box Weight	Box Size	Item Weight	Item Dimensions	FSC	FSG	NIIN	INC
--	--	--	--	8030	80	01-476-2407 / 014762407	03268

National Motor Freight / Schedule B

NMFC	Description	Schedule B
149980	PAINT AND RELATED MATERIALS	3214100010 / Caulking compounds

8040-01-470-3260

Adhesive

COLOR: BLUE
FEATURES PROVIDED: SEPARATE CATALYST
MATERIAL: PLASTIC EPOXY
QUANTITY WITHIN EACH UNIT PACKAGE: 1.000 GALLONS
RATED DRYING TIME: 120.000 HOURS MINIMUM AND 168.000 HOURS MAXIMUM
PHYSICAL FORM: PASTE
SPECIFIC USAGE DESIGN: FOR AEROSPACE POTTING AND EDGE FILLING APPLICATIONS
SPECIAL FEATURES: ROOM TEMPERATURE CURE; SYNTACTIC; LOW DENSITY; STORE AT 40 DEG F OR BELOW
SUPPLEMENTARY FEATURES: 1 GALLON KIT

Weight and Dimensions

National Stock Number

Box Weight	Box Size	Item Weight	Item Dimensions	FSC	FSG	NIIN	INC
--	180 X 260 X 180	--	--	8040	80	01-470-3260 / 014703260	11297

National Motor Freight / Schedule B

NMFC	Description	Schedule B
004620	ADHESIVES:CEMENTS,GLUES,PASTES	

MIL-PRF-23377K Type I, class C2-

Epoxy Primer Coating Kit

APPLICATION METHOD:	SPRAYING AS IS OR SPRAYING AFTER THINNING
COLOR:	YELLOW
CONTENT WITHIN EACH UNIT PACKAGE:	CONSISTS OF COMPONENT A (EPOXY RESIN AND SOLVENTS) AND COMPONENT B (POLYAMIDE AND/OR AMINE RESIN AND SOLVENTS) TO EQUAL 2 QUARTS
ENVIRONMENTAL ATTRIBUTE CODE:	LOW VOLATILE ORGANIC COMPOUND - COATINGS - AEROSPACE OPERATIONS COATINGS
FEATURES PROVIDED:	FLAMMABLE
NONDEFINITIVE SPEC/STD DATA:	1 TYPE AND C2 CLASS
QUANTITY WITHIN EACH UNIT PACKAGE:	2.000 QUARTS
RATED DRYING TIME:	5.000 HOURS MAXIMUM
PIGMENT MATERIAL TYPE:	STRONTIUM CHROMATE
SPECIFIC USE:	AIRCRAFT SURFACES
SPECIAL FEATURES:	STANDARD PIGMENTS; FOR GENERAL USE AS A CORROSION INHIBITIVE, CHEMICAL RESISTANT, STRIPPABLE PRIMER
VEHICLE MATERIAL TYPE:	EPOXY RESIN AND POLYAMIDE RESIN
VOLATILE ORGANIC COMPOUND IN GRAMS PER LITER:	340.0

Weight and Dimensions

National Stock Number

Box Weight	Box Size	Item Weight	Item Dimensions	FSC	FSG	NIIN	INC
--	--	--	--	8010	80	01-416-6556 / 014166556	29687

National Motor Freight / Schedule B

NMFC	Description	Schedule B
149980	PAINT AND RELATED MATERIALS	

8030-00-152-0021

Sealing Compound

COLOR:	RED
FEATURES PROVIDED:	SEPARATE CATALYST
MATERIAL:	RUBBER SYNTHETIC
NONDEFINITIVE SPEC/STD DATA:	1 TYPE AND B-1/2 CLASS
QUANTITY WITHIN EACH UNIT PACKAGE:	4.500 OUNCES
RATED DRYING TIME:	10.000 HOURS NOMINAL
PHYSICAL FORM:	PASTE
SPECIAL FEATURES:	LOW ADHESION; NON-CORROSION INHIBITING; POLYSULFIDE; 1/2 HOUR WORKING TIME; SERVICE TEMPERATURE RANGE OF MINUS 67 DEG F TO PLUS 250 DEG F
SPECIFIC USAGE DESIGN:	FOR AIRCRAFT ACCESS DOORS
SPECIFICATION/STANDARD DATA:	81343-AMS3284 PROFESSIONAL/INDUSTRIAL ASSOCIATION STANDARD
SUPPLEMENTARY FEATURES:	4-1/2 OUNCE IN 6 OUNCE CARTRIDGE

Weight and Dimensions

National Stock Number

Box Weight	Box Size	Item Weight	Item Dimensions	FSC	FSG	NIIN	INC
--	--	--	--	8030	80	00-152-0021 / 001520021	03268

National Motor Freight / Schedule B

NMFC	Description	Schedule B
149980	PAINT AND RELATED MATERIALS	3214100010 / Caulking compounds

K16633KEF-LVOC_Q

Epoxy Coating Kit

APPLICATION METHOD:	SPRAYING AS IS OR SPRAYING AFTER THINNING
COLOR CHIP NUMBER:	37038
COLOR:	BLACK
CONTENT WITHIN EACH UNIT PACKAGE:	CONSISTS OF COMPONENT A (EPOXY RESIN AND SOLVENTS) AND COMPONENT B (POLYAMIDE AND/OR AMINE RESIN AND SOLVENTS) TO EQUAL 2 QUARTS
ENVIRONMENTAL ATTRIBUTE CODE:	LOW VOLATILE ORGANIC COMPOUND - COATINGS - AEROSPACE OPERATIONS COATINGS
FEATURES PROVIDED:	LEAD FREE AND CHROMATE FREE
FINISH FOR WHICH FORMULATED:	FINE
GLOSS DESIGNATION:	FLAT
NONDEFINITIVE SPEC/STD DATA:	1 TYPE AND H CLASS AND B GRADE
QUANTITY WITHIN EACH UNIT PACKAGE:	2.000 QUARTS
SPECIAL FEATURES:	STANDARD FORMULATION; HIGH SOLIDS; SOLVENT BASE; FOR INTERIOR OF TACTICAL EQUIPMENT NOT REQUIRING WEATHER RESISTANCE
VEHICLE MATERIAL TYPE:	EPOXY RESIN AND POLYAMIDE RESIN
VOLATILE ORGANIC COMPOUND IN GRAMS PER LITER:	340.0
:	222126
:	222126

Weight and Dimensions

National Stock Number

Box Weight	Box Size	Item Weight	Item Dimensions	FSC	FSG	NIIN	INC
--		--	--	8010	80	01-419-1142 / 014191142	29686

National Motor Freight / Schedule B

NMFC	Description	Schedule B
004630	ADHESIVES OR EPOXY RESINS	3907300000 / Epoxide resins

P/S 870B1/2

Sealing Compound

COLOR:	GRAY
FEATURES PROVIDED:	SEPARATE CATALYST
MATERIAL:	RUBBER SYNTHETIC
NONDEFINITIVE SPEC/STD DATA:	1 TYPE AND 1 CLASS AND A GRADE
QUANTITY WITHIN EACH UNIT PACKAGE:	1.000 QUARTS
RATED DRYING TIME:	7.000 DAYS NOMINAL
PHYSICAL FORM:	LIQUID
SPECIAL FEATURES:	CONTAINS CHROMATES; FOR BRUSH OR DIP APPLICATION; POLYSULFIDE; 2 HOUR WORKING TIME
SPECIFIC USAGE DESIGN:	CORROSION PROTECTION FOR INTERIOR/EXTERIOR AIRCRAFT AND WEAPONS; NOT FOR INTEGRAL FUEL TANKS
SUPPLEMENTARY FEATURES:	24 FLUID OUNCE BASE AND REQUIRED AMOUNT OF CURING AGENT IN SEPARATE CONTAINERS

Weight and Dimensions

National Stock Number

Box Weight	Box Size	Item Weight	Item Dimensions	FSC	FSG	NIIN	INC
--	--	--	--	8030	80	00-762-8807 / 007628807	03268

National Motor Freight / Schedule B

NMFC	Description	Schedule B
149980	PAINT AND RELATED MATERIALS	3214100010 / Caulking compounds

PS870B1-2PTM

Sealing Compound

COLOR:	GRAY
FEATURES PROVIDED:	SEPARATE CATALYST
MATERIAL:	RUBBER SYNTHETIC
NONDEFINITIVE SPEC/STD DATA:	2 TYPE AND 1 CLASS AND A GRADE
QUANTITY WITHIN EACH UNIT PACKAGE:	1.000 PINTS
RATED DRYING TIME:	14.000 DAYS NOMINAL
PHYSICAL FORM:	LIQUID
SPECIAL FEATURES:	CONTAINS CHROMATES; FOR EXTRUSION APPLICATION, GUN OR SPATULA; POLYSULFIDE; 1/2 HOUR WORKING TIME
SPECIFIC USAGE DESIGN:	CORROSION PROTECTION FOR INTERIOR/EXTERIOR AIRCRAFT AND WEAPONS; NOT FOR INTEGRAL FUEL TANKS
SUPPLEMENTARY FEATURES:	12 FLUID OUNCE BASE AND REQUIRED AMOUNT OF CURING AGENT IN SEPARATE CONTAINERS

Weight and Dimensions

National Stock Number

Box Weight	Box Size	Item Weight	Item Dimensions	FSC	FSG	NIIN	INC
--		--	--	8030	80	00-008-7198 / 000087198	03268

National Motor Freight / Schedule B

NMFC	Description	Schedule B
149980	PAINT AND RELATED MATERIALS	3214100010 / Caulking compounds

PR-1826 A-1/2

Sealing Compound

COLOR: GRAY
FEATURES PROVIDED: SEPARATE CATALYST
MATERIAL: RUBBER SYNTHETIC
QUANTITY WITHIN EACH UNIT PACKAGE: 2.000 OUNCES
RATED DRYING TIME: 2.000 HOURS NOMINAL
PHYSICAL FORM: PASTE
SPECIAL FEATURES: FAST CURING; SERVICE TEMPERATURE RANGE OF MINUS 65 DEG F TO PLUS 320 DEG F, INTERMITTENT USE TO 360 DEG F; POLYTHIOETHER; 1/2 HOUR WORKING TIME
SPECIFIC USAGE DESIGN: FOR AIRCRAFT INTEGRAL FUEL TANKS
SUPPLEMENTARY FEATURES: 2 OUNCE IN 2-1/2 OUNCE CARTRIDGE AND REQUIRED AMOUNT OF PRIMER IN SEPARATE CONTAINER

Weight and Dimensions

National Stock Number

Box Weight	Box Size	Item Weight	Item Dimensions	FSC	FSG	NIIN	INC
--	--	--	--	8030	80	01-330-6568 / 013306568	03268

National Motor Freight / Schedule B

NMFC	Description	Schedule B
149980	PAINT AND RELATED MATERIALS	3214100010 / Caulking compounds

8010-01-265-9139

Polyurethane Coating

APPLICATION METHOD: SPRAYING AS IS
BASIC FORMULATION TYPE: POLYURETHANE
COLOR CHIP NUMBER: 11136
COLORING METHOD: PIGMENTED
COLOR: RED
CONTENT WITHIN EACH UNIT PACKAGE: CONSISTS OF COMPONENT A (PIGMENTED POLYESTER RESIN AND SOLVENT) AND COMPONENT B (CLEAR ALIPHATIC ISOCYANATE) TO EQUAL 2 GALLONS
ENVIRONMENTAL ATTRIBUTE CODE: LOW VOLATILE ORGANIC COMPOUND - COATINGS - AEROSPACE OPERATIONS COATINGS AND PLASTICS REMOVAL IN THE MARINE ENVIRONMENT (PRIME) PRODUCT
FEATURES PROVIDED: LEAD FREE AND CHROMATE FREE
GLOSS DESIGNATION: GLOSS
NONDEFINITIVE SPEC/STD DATA: 1 TYPE AND H CLASS
QUANTITY WITHIN EACH UNIT PACKAGE: 2.000 GALLONS
RATED DRYING TIME: 6.000 HOURS MAXIMUM
SPECIAL FEATURES: HIGH SOLIDS
SPECIFIC USE: AIRCRAFT SURFACES
VOLATILE ORGANIC COMPOUND IN GRAMS PER LITER: 420.0
:
:

Weight and Dimensions

Box Weight	Box Size	Item Weight	Item Dimensions
--	--	--	--

National Motor Freight / Schedule B

NMFC	Description	Schedule B
------	-------------	------------

149980

PAINT AND RELATED
MATERIALS

3909506000 / Polyurethanes, except
elastomeric

National Stock Number

FSC	FSG	NIIN	INC
8010	80	01-265-9139 / 012659139	29027

8040-01-487-7705

Adhesive

COLOR: SILVER
MATERIAL: PLASTIC EPOXY
QUANTITY WITHIN EACH UNIT PACKAGE: 0.500 OUNCES
RATED DRYING TIME: 24.000 HOURS NOMINAL
PHYSICAL FORM: PASTE
SPECIFIC USAGE DESIGN: FOR ELECTRONICS BONDING APPLICATIONS
SPECIAL FEATURES: SILVER FILLED; ELECTRICALLY CONDUCTIVE; ROOM TEMPERATURE OR ELEVATED TEMPERATURE CURE; 24 HOURS AT ROOM TEMPERATURE OR 2 HOURS AT 60 DEG C
SUPPLEMENTARY FEATURES: 1/2 OUNCE KIT

National Stock Number

FSC	FSG	NIIN	INC
8040	80	01-487-7705 / 014877705	11297

AC-735 B-1/2, PT KIT

Sealing Compound

COLOR:	GRAY
FEATURES PROVIDED:	SEPARATE CATALYST
MATERIAL:	RUBBER SYNTHETIC
NONDEFINITIVE SPEC/STD DATA:	1 TYPE AND 1 CLASS AND A GRADE
QUANTITY WITHIN EACH UNIT PACKAGE:	1.000 PINTS
RATED DRYING TIME:	7.000 DAYS NOMINAL
PHYSICAL FORM:	LIQUID
SPECIAL FEATURES:	CONTAINS CHROMATES; FOR BRUSH OR DIP APPLICATION; POLYSULFIDE; 2 HOUR WORKING TIME
SPECIFIC USAGE DESIGN:	CORROSION PROTECTION FOR INTERIOR/EXTERIOR AIRCRAFT AND WEAPONS; NOT FOR INTEGRAL FUEL TANKS
SUPPLEMENTARY FEATURES:	12 FLUID OUNCE BASE AND REQUIRED AMOUNT OF CURING AGENT IN SEPARATE CONTAINERS

Weight and Dimensions

National Stock Number

Box Weight	Box Size	Item Weight	Item Dimensions	FSC	FSG	NIIN	INC
--		--	--	8030	80	00-008-7196 / 000087196	03268

National Motor Freight / Schedule B

NMFC	Description	Schedule B
149980	PAINT AND RELATED MATERIALS	3214100010 / Caulking compounds

LD3003985

Adhesive Primer

COLOR: COLORLESS
QUANTITY WITHIN EACH UNIT PACKAGE: 1.000 GALLONS
PHYSICAL FORM: LIQUID
SPECIAL FEATURES: ETHYL ACETATE SOLVENT BASE
SUPPLEMENTARY FEATURES: 1 GALLON CAN
USAGE DESIGN: FOR PROMOTING ADHESION OF POLYMERIC ELASTOMERS

Weight and Dimensions

National Stock Number

Box Weight	Box Size	Item Weight	Item Dimensions	FSC	FSG	NIIN	INC
--		--	--	8040	80	01-151-4258 / 011514258	23128

National Motor Freight / Schedule B

NMFC	Description	Schedule B
004630	ADHESIVES OR EPOXY RESINS	3814000000 / Organic composite solvents and thinners, not elsewhere specified or included; prepared paint or varnish removers

FA-1041

Adhesive

COLOR: CREAM
MATERIAL: RUBBER NEOPRENE
QUANTITY WITHIN EACH UNIT PACKAGE: 1.000 PINTS
PHYSICAL FORM: PASTE
SPECIFIC USAGE DESIGN: FOR REPAIRING DIVERS' WET SUITS
SUPPLEMENTARY FEATURES: 1 PINT CAN

Weight and Dimensions

National Stock Number

Box Weight	Box Size	Item Weight	Item Dimensions	FSC	FSG	NIIN	INC
--		--	--	8040	80	00-440-5603 / 004405603	11297

National Motor Freight / Schedule B

NMFC	Description	Schedule B
004620	ADHESIVES:CEMENTS,GLUES,PASTES	

MMMA134TY2

Adhesive

FEATURES PROVIDED:	SEPARATE CATALYST AND HEAT VULCANIZE FEATURE
MATERIAL:	PLASTIC EPOXY
NONDEFINITIVE SPEC/STD DATA:	2 TYPE
QUANTITY WITHIN EACH UNIT PACKAGE:	1.000 PINTS
PHYSICAL FORM:	LIQUID
SPECIAL FEATURES:	INTERMEDIATE TEMPERATURE SETTING
SPECIFIC USAGE DESIGN:	STRUCTURAL ADHESIVE FOR BONDING METAL TO METAL PARTS
SUPPLEMENTARY FEATURES:	1 PINT KIT

Weight and Dimensions

National Stock Number

Box Weight	Box Size	Item Weight	Item Dimensions	FSC	FSG	NIIN	INC
--	--	--	--	8040	80	00-691-1322 / 006911322	11297

National Motor Freight / Schedule B

NMFC	Description	Schedule B
004620	ADHESIVES:CEMENTS,GLUES,PASTES	

V-09C

Adhesive Primer

END ITEM IDENTIFICATION:

COLOR:

MINIMUM FLASH POINT:

PART NAME ASSIGNED BY CONTROLLING AGENCY:

PHYSICAL FORM:

SPECIAL FEATURES:

SPECIFIC USAGE DESIGN:

F/A-22 RAPTOR

CLEAR

10.0 DEG CELSIUS

RHODORSIL V-09C

LIQUID

COMES IN A SIX-POUND GALLON, SHELF LIFE IS 18 MONTHS

PROMOTES OR IMPROVES ADHESION

National Stock Number

FSC	FSG	NIIN	INC
8040	80	01-529-5061 / 015295061	23128

52-03-2044-0000

Sealing Compound

COLOR: GRAY
MATERIAL: PLASTIC ACRYLIC
QUANTITY WITHIN EACH UNIT PACKAGE: 1.000 GALLONS
RATED DRYING TIME: 24.000 HOURS NOMINAL
PHYSICAL FORM: LIQUID
SPECIAL FEATURES: NICKEL FILLED; ELECTRICALLY CONDUCTIVE; SOLVENT RESISTANT; FOR USE ON ABS, NORYL AND POLYESTER PLASTICS
SPECIFIC USAGE DESIGN: FOR EMI SHIELDING APPLICATIONS
SUPPLEMENTARY FEATURES: 1 GALLON CAN

National Motor Freight / Schedule B

National Stock Number

NMFC	Description	Schedule B	FSC	FSG	NIIN	INC
194120	WASHERS/GASKETS/PCKG DVCS	3214100010 / Caulking compounds	8030	80	01-156-7567 / 011567567	03268

LA-4220

Adhesive

END ITEM IDENTIFICATION: NSN 4240-01-016-0888 E-3A AIRCRAFT ESCAPE SLIDE
 FEATURES PROVIDED: SEPARATE CATALYST
 MATERIAL: PLASTIC POLYURETHANE
 QUANTITY WITHIN EACH UNIT PACKAGE: 1.000 QUARTS
 PHYSICAL FORM: LIQUID
 SPECIFIC USAGE DESIGN: FOR REPAIRING AIRCRAFT ESCAPE SLIDE
 SUPPLEMENTARY FEATURES: 1 QUART KIT

Weight and Dimensions

National Stock Number

Box Weight	Box Size	Item Weight	Item Dimensions	FSC	FSG	NIIN	INC
--	--	--	--	8040	80	01-303-0401 / 013030401	11297

National Motor Freight / Schedule B

NMFC	Description	Schedule B
004620	ADHESIVES:CEMENTS,GLUES,PASTES	

8030-01-499-0438

Sealing Compound

COLOR: OLIVE DRAB
FEATURES PROVIDED: SEPARATE CATALYST
MATERIAL: SILICONE
QUANTITY WITHIN EACH UNIT PACKAGE: 3.500 OUNCES
PHYSICAL FORM: PASTE
SPECIAL FEATURES: NICKEL FILLED; ELECTRICALLY CONDUCTIVE
SPECIFIC USAGE DESIGN: FOR EMI AND RFI SHIELDING APPLICATIONS
SUPPLEMENTARY FEATURES: 3-1/2 OUNCE IN 6 OUNCE CARTRIDGE

Weight and Dimensions

National Stock Number

Box Weight	Box Size	Item Weight	Item Dimensions	FSC	FSG	NIIN	INC
--	--	--	--	8030	80	01-499-0438 / 014990438	03268

National Motor Freight / Schedule B

NMFC	Description	Schedule B
149980	PAINT AND RELATED MATERIALS	3214100010 / Caulking compounds

8030-01-499-0438

Sealing Compound

COLOR: OLIVE DRAB
FEATURES PROVIDED: SEPARATE CATALYST
MATERIAL: SILICONE
QUANTITY WITHIN EACH UNIT PACKAGE: 3.500 OUNCES
PHYSICAL FORM: PASTE
SPECIAL FEATURES: NICKEL FILLED; ELECTRICALLY CONDUCTIVE
SPECIFIC USAGE DESIGN: FOR EMI AND RFI SHIELDING APPLICATIONS
SUPPLEMENTARY FEATURES: 3-1/2 OUNCE IN 6 OUNCE CARTRIDGE

Weight and Dimensions

National Stock Number

Box Weight	Box Size	Item Weight	Item Dimensions	FSC	FSG	NIIN	INC
--	--	--	--	8030	80	01-499-0438 / 014990438	03268

National Motor Freight / Schedule B

NMFC	Description	Schedule B
149980	PAINT AND RELATED MATERIALS	3214100010 / Caulking compounds

8010-00-935-7079

Lacquer

APPLICATION METHOD:	SPRAYING AS IS
BASIC MATERIAL TYPE:	ACRYLIC RESIN
COLOR CHIP NUMBER:	37038
COLORING METHOD:	PIGMENTED
COLOR:	BLACK
ENVIRONMENTAL ATTRIBUTE CODE:	LOW VOLATILE ORGANIC COMPOUND - COATINGS - AEROSPACE OPERATIONS COATINGS
FEATURES PROVIDED:	AEROSOL CAN AND LEAD FREE AND CHROMATE FREE
GLOSS DESIGNATION:	FLAT
NONDEFINITIVE SPEC/STD DATA:	1 TYPE
QUANTITY WITHIN EACH UNIT PACKAGE:	16.000 OUNCES
RATED DRYING TIME:	40.000 MINUTES MAXIMUM
SPECIAL FEATURES:	FOR USE AS AN EXTERIOR TOUCH-UP COATING OVER EPOXY PRIMER CONFORMING TO MIL-PRF-23377 OR MIL-P-85582; 12.25 OZ NET WEIGHT CAN
SPECIFIC USE:	AIRCRAFT SURFACES
VOLATILE ORGANIC COMPOUND IN GRAMS PER LITER:	340.0
:	222126
:	222126
:	222126

Weight and Dimensions

National Stock Number

Box Weight	Box Size	Item Weight	Item Dimensions	FSC	FSG	NIIN	INC
--	--	--	--	8010	80	00-935-7079 / 009357079	06430

National Motor Freight / Schedule B

NMFC	Description	Schedule B
149980	PAINT AND RELATED MATERIALS	

8010-00-935-6609

Lacquer

APPLICATION METHOD: SPRAYING AS IS
 BASIC MATERIAL TYPE: ACRYLIC RESIN
 COLOR CHIP NUMBER: 17875
 COLORING METHOD: PIGMENTED
 COLOR: WHITE
 ENVIRONMENTAL ATTRIBUTE CODE: LOW VOLATILE ORGANIC COMPOUND - COATINGS - AEROSPACE OPERATIONS COATINGS
 FEATURES PROVIDED: AEROSOL CAN AND LEAD FREE AND CHROMATE FREE
 GLOSS DESIGNATION: GLOSS
 NONDEFINITIVE SPEC/STD DATA: 1 TYPE
 QUANTITY WITHIN EACH UNIT PACKAGE: 16.000 OUNCES
 RATED DRYING TIME: 40.000 MINUTES MAXIMUM
 SPECIAL FEATURES: FOR USE AS AN EXTERIOR TOUCH-UP COATING OVER EPOXY PRIMER CONFORMING TO MIL-PRF-23377 OR MIL-P-85582; 12.25 OZ NET WEIGHT CAN
 SPECIFIC USE: AIRCRAFT SURFACES
 VOLATILE ORGANIC COMPOUND IN GRAMS PER LITER: 340.0
 : eff5e7
 : eff5e7
 : eff5e7

Weight and Dimensions

National Stock Number

Box Weight	Box Size	Item Weight	Item Dimensions	FSC	FSG	NIIN	INC
--	--	--	--	8010	80	00-935-6609 / 009356609	06430

National Motor Freight / Schedule B

NMFC	Description	Schedule B
149980	PAINT AND RELATED MATERIALS	

8020-00-598-5907

Artist's Brush

FERRULE MATERIAL:	METAL
HANDLE:	FURNISHED
NONDEFINITIVE SPEC/STD DATA:	2 TYPE AND 2 CLASS AND A STYLE
STOCK EXPOSED LENGTH:	0.813 INCHES MINIMUM
STOCK MATERIAL TYPE:	SABELINE
STOCK MATERIAL:	HAIR, RED SABLE
STOCK DIAMETER AT FERRULE:	0.203 INCHES MINIMUM
STYLE DESIGNATOR:	ROUND, TAPER POINT

Weight and Dimensions

National Stock Number

Box Weight	Box Size	Item Weight	Item Dimensions	FSC	FSG	NIIN	INC
--		--	--	8020	80	00-598-5907 / 005985907	16881

National Motor Freight / Schedule B

NMFC	Description	Schedule B
014540	ARTISTS MATERIALS R PAINTS	9603300000 / Artists; brushes, writing brushes and similar brushes for the application of cosmetics

8010-01-528-4858

Polyurethane Coating

APPLICATION METHOD:	SPRAYING AS IS
BASIC FORMULATION TYPE:	POLYURETHANE
COLOR CHIP NUMBER:	36320
COLOR:	GRAY
COLORING METHOD:	PIGMENTED
CONTENT WITHIN EACH UNIT PACKAGE:	SIX 16 OZ AEROSOL CANS (11 TO 12 OZ NET WEIGHT PER CAN)
ENVIRONMENTAL ATTRIBUTE CODE:	LOW VOLATILE ORGANIC COMPOUND - COATINGS - AEROSPACE OPERATIONS COATINGS
FEATURES PROVIDED:	AEROSOL CAN AND LEAD FREE AND CHROMATE FREE
GLOSS DESIGNATION:	FLAT
NONDEFINITIVE SPEC/STD DATA:	1 TYPE AND H CLASS
RATED DRYING TIME:	6.000 HOURS MAXIMUM
SPECIAL FEATURES:	HIGH SOLIDS
SPECIFIC USE:	AIRCRAFT SURFACES
VOLATILE ORGANIC COMPOUND IN GRAMS PER LITER:	420.0
:	849199

Weight and Dimensions

National Stock Number

Box Weight	Box Size	Item Weight	Item Dimensions	FSC	FSG	NIIN	INC
--	--	--	--	8010	80	01-528-4858 / 015284858	29027

National Motor Freight / Schedule B

NMFC	Description	Schedule B
149980	PAINT AND RELATED MATERIALS	3909506000 / Polyurethanes, except elastomeric

EA9321

Adhesive

COLOR: GRAY
FEATURES PROVIDED: SEPARATE CATALYST
MATERIAL: PLASTIC EPOXY
QUANTITY WITHIN EACH UNIT PACKAGE: 1.000 QUARTS
RATED DRYING TIME: 120.000 HOURS MINIMUM AND 168.000 HOURS MAXIMUM
PHYSICAL FORM: PASTE
SPECIAL FEATURES: THIXOTROPIC; ROOM TEMPERATURE CURE; RETAINS STRENGTH AT ELEVATED TEMPERATURES
SPECIFIC USAGE DESIGN: FOR AEROSPACE BONDING APPLICATIONS
SUPPLEMENTARY FEATURES: 1 QUART KIT

Weight and Dimensions

National Stock Number

Box Weight	Box Size	Item Weight	Item Dimensions	FSC	FSG	NIIN	INC
--	--	--	--	8040	80	01-193-6717 / 011936717	11297

National Motor Freight / Schedule B

NMFC	Description	Schedule B
004620	ADHESIVES:CEMENTS,GLUES,PASTES	

PR-1725 B-2

Sealing Compound

COLOR: GRAY
FEATURES PROVIDED: SEPARATE CATALYST
MATERIAL: RUBBER SYNTHETIC
QUANTITY WITHIN EACH UNIT PACKAGE: 1.000 QUARTS
PHYSICAL FORM: LIQUID
SPECIFIC USAGE DESIGN: FOR HIGH SPEED AIRCRAFT WINDOWS AND WINDSHIELD APPLICATIONS
SPECIAL FEATURES: POLYSULFIDE; 2 HOUR WORKING TIME
SUPPLEMENTARY FEATURES: 1 QUART KIT

Weight and Dimensions

National Stock Number

Box Weight	Box Size	Item Weight	Item Dimensions	FSC	FSG	NIIN	INC
--		--	--	8030	80	01-118-4083 / 011184083	03268

National Motor Freight / Schedule B

NMFC	Description	Schedule B
149980	PAINT AND RELATED MATERIALS	3214100010 / Caulking compounds

MIL-DTL-450D, Comp. L, Type II

Solv Bituminous Coating Compound

MATERIAL: ASPHALT
NONDEFINITIVE SPEC/STD DATA: L COMPOSITION AND 2 TYPE
QUANTITY WITHIN EACH UNIT PACKAGE: 1.000 GALLONS
SOLID CONTENT PERCENTAGE: 45.0
SUPPLEMENTARY FEATURES: 1 GALLON CAN
USAGE DESIGN: FOR COATING SURFACES OF AMMUNITION CAVITIES PRIOR TO FILLING WITH EXPLOSIVES

Weight and Dimensions

National Stock Number

Box Weight	Box Size	Item Weight	Item Dimensions	FSC	FSG	NIIN	INC
--		--	--	8030	80	00-290-5141 / 002905141	15966

National Motor Freight / Schedule B

NMFC	Description	Schedule B
149980	PAINT AND RELATED MATERIALS	2715000000 / Bituminous mixtures based on natural asphalt, natural bitumen, petroleum bitumen, mineral tar or mineral tar pitch

8030-00-753-5006

Sealing Compound

FEATURES PROVIDED:	SEPARATE CATALYST
MATERIAL:	RUBBER SYNTHETIC
NONDEFINITIVE SPEC/STD DATA:	2 TYPE AND B-2 CLASS
QUANTITY WITHIN EACH UNIT PACKAGE:	2.000 OUNCES
RATED DRYING TIME:	40.000 HOURS NOMINAL
PHYSICAL FORM:	PASTE
SPECIFIC USAGE DESIGN:	FOR AIRCRAFT INTEGRAL FUEL TANKS AND FUEL CELL CAVITIES
SPECIFICATION/STANDARD DATA:	81343-AMS-S-8802 PROFESSIONAL/INDUSTRIAL ASSOCIATION STANDARD
SPECIAL FEATURES:	SERVICE TEMPERATURE RANGE OF MINUS 65 DEG F TO PLUS 250 DEG F; POLYSULFIDE; 2 HOUR WORKING TIME
SUPPLEMENTARY FEATURES:	2 OUNCE IN 2-1/2 OUNCE CARTRIDGE

Weight and Dimensions

National Stock Number

Box Weight	Box Size	Item Weight	Item Dimensions	FSC	FSG	NIIN	INC
--	--	--	--	8030	80	00-753-5006 / 007535006	03268

National Motor Freight / Schedule B

NMFC	Description	Schedule B
149980	PAINT AND RELATED MATERIALS	3214100010 / Caulking compounds

8030-00-546-8637

Corrosion Preventive Compound

APPLICATION TYPE: COLD
FILM THICKNESS: 0.0002 INCHES MAXIMUM
FILM HARDNESS DESIGNATION: SOFT
NONDEFINITIVE SPEC/STD DATA: 3 TYPE AND 2 CLASS AND 134A GRADE
QUANTITY WITHIN EACH UNIT PACKAGE: 16.000 OUNCES
SPECIAL FEATURES: WATER DISPLACING; SOFT FILM; AVIONIC GRADE
SUPPLEMENTARY FEATURES: 16 OUNCE AEROSOL CAN (14.5 OZ NET WEIGHT)
USAGE DESIGN: FOR PROTECTION OF METAL SURFACES IN INDOOR ENVIRONMENTS AND FOR SHORT TERM OUTDOOR PROTECTION

Weight and Dimensions

National Stock Number

Box Weight	Box Size	Item Weight	Item Dimensions	FSC	FSG	NIIN	INC
--		--	--	8030	80	00-546-8637 / 005468637	16687

National Motor Freight / Schedule B

NMFC	Description	Schedule B
050234	COMPOUNDS I/S RUST PREVENTING	

6663-2 Qt Kit

Potting Compound

GENERAL CHARACTERISTICS ITEM DESCRIPTION:

EPOXY; ROOM TEMPERATURE CURE

SUPPLEMENTARY FEATURES:

1 QUART KIT; MINIMUM ORDER IS 8 KITS

Weight and Dimensions

National Stock Number

Box Weight	Box Size	Item Weight	Item Dimensions	FSC	FSG	NIIN	INC
--	--	--	--	8030	80	00-463-7053 / 004637053	7777

National Motor Freight / Schedule B

NMFC	Description	Schedule B
004630	ADHESIVES OR EPOXY RESINS	

0519X303XXCAS12K

Primer Coating

PART NAME ASSIGNED BY CONTROLLING AGENCY:

HIGH TEMPERATURE COATING

National Stock Number

FSC	FSG	NIIN	INC
8010	80	01-550-3503 / 015503503	15705

0529K002XXCAS12K

Heat Resisting Enamel

COLOR:	ALUMINUM
CONTENT WITHIN EACH UNIT PACKAGE:	TWENTY-FOUR 10 CC PENS
RATED DRYING TIME:	30.000 MINUTES MINIMUM AND 60.000 MINUTES MAXIMUM
SPECIAL FEATURES:	FUEL, OIL AND CORROSION RESISTANT; COATS ALUMINUM AND MAGNESIUM ALLOYS; HEAT RESISTANT TO 400 DEG F
SPECIFIC USE:	AIRCRAFT SURFACES
TEMP RATING:	450.0 DEG FAHRENHEIT NOMINAL
VEHICLE MATERIAL TYPE:	EPOXY RESIN
VOLATILE ORGANIC COMPOUND IN GRAMS PER LITER:	698.0

Weight and Dimensions

National Stock Number

Box Weight	Box Size	Item Weight	Item Dimensions	FSC	FSG	NIIN	INC
--		--	--	8010	80	01-494-6157 / 014946157	18948

National Motor Freight / Schedule B

NMFC	Description	Schedule B
149980	PAINT AND RELATED MATERIALS	

MIL-PRF-85285 T1 / FCS 37875

Polyurethane Coating

APPLICATION METHOD:	SPRAYING AS IS
BASIC FORMULATION TYPE:	POLYURETHANE
COLOR CHIP NUMBER:	37875
COLORING METHOD:	PIGMENTED
COLOR:	WHITE
CONTENT WITHIN EACH UNIT PACKAGE:	CONSISTS OF COMPONENT A (PIGMENTED POLYESTER RESIN AND SOLVENT) AND COMPONENT B (CLEAR ALIPHATIC ISOCYANATE) TO EQUAL 2 QUARTS
ENVIRONMENTAL ATTRIBUTE CODE:	LOW VOLATILE ORGANIC COMPOUND - COATINGS - AEROSPACE OPERATIONS COATINGS
FEATURES PROVIDED:	LEAD FREE AND CHROMATE FREE
GLOSS DESIGNATION:	FLAT
NONDEFINITIVE SPEC/STD DATA:	1 TYPE AND H CLASS
QUANTITY WITHIN EACH UNIT PACKAGE:	2.000 QUARTS
RATED DRYING TIME:	6.000 HOURS MAXIMUM
SPECIAL FEATURES:	HIGH SOLIDS
SPECIFIC USE:	AIRCRAFT SURFACES
VOLATILE ORGANIC COMPOUND IN GRAMS PER LITER:	420.0
:	eff5e7
:	eff5e7

Weight and Dimensions

Box Weight	Box Size	Item Weight	Item Dimensions
--	--	--	--

National Motor Freight / Schedule B

NMFC	Description	Schedule B
------	-------------	------------

149980

PAINT AND RELATED
MATERIALS

3909506000 / Polyurethanes, except
elastomeric

National Stock Number

FSC	FSG	NIIN	INC
8010	80	01-397-3982 / 013973982	29027

BOSTIK 9252

Aircra Metal Primer

: ENVELOPE MATERIAL:GLASS AND METAL; MANUFACTURER CLASSIFICATION:CROSSED FIELD AMPLIFIER: NAVICP-M PROJECT TO ASSIGN CRITICALITY CODE "Y"|"FEAT

: BALANCED "O"|"AEBZ

: BRIDGED "T"|"AEBZ

: SPECIAL "CD"|"CZHQ

: SPECIAL "CD"|"CZHQ

: TWO BEND MODIFIED "U"|"STYL

: TWO BEND MODIFIED "U"|"STYL

: BRIDGED "T"|"AEBZ

: "T"|"AEBZ

: FOUR 26 FOOT LENGTHS 104 FT/WDN SPOOL,OLIVE DRAB OR SAND COLOR,F/APERS PRAC MINE M8,ALSO 1 SPOOL PACKED W/EA M16/M16A1 APERS MINE,ALSO 6 SPOOLS PACKED W/ EA XM10 SPIDER MCU KIT, DODAC CODE 1346-K013,PACKED AS REQUIRED; PACKAGE REFERENCE NUMBER: MS1169"|"FEAT

: PENDING USER COORDINATION THIS ITEM TO BE REPLACE BY NSN 2910-00-784-5351; SOS S9C"|"FEAT

: UNBALANCED "LL"|"AEBZ

: WORDS "ON" AND "OFF"|"ASKN

: EMI "D"|"AAGR

: TWO BENDS"|"STYL

: MARKED "NEGATIVE" ON ONE SIDE OF ENGAGING KMARKGMARKED "UG-119/U"|"MARK

: STAMPED "A-809"|"MARK

National Stock Number

FSC	FSG	NIIN	INC
-----	-----	------	-----

-- /

8040-00-894-2269

Adhesive

COLOR: CLEAR
FEATURES PROVIDED: SEPARATE CATALYST
MATERIAL: PLASTIC EPOXY
PHYSICAL FORM: LIQUID
SPECIFIC USAGE DESIGN: FOR GENERAL PURPOSE BONDING APPLICATIONS
SUPPLEMENTARY FEATURES: TWELVE 1 QUART KITS

Weight and Dimensions

National Stock Number

Box Weight	Box Size	Item Weight	Item Dimensions	FSC	FSG	NIIN	INC
--	--	--	--	8040	80	00-894-2269 / 008942269	11297

National Motor Freight / Schedule B

NMFC	Description	Schedule B
004620	ADHESIVES:CEMENTS,GLUES,PASTES	

SOLITHANE Resin 113/C113-300

Thermosetting Resin Coating

END ITEM IDENTIFICATION:

B-1

COLOR:

YELLOW

PART NAME ASSIGNED BY CONTROLLING AGENCY:

RESIN COATING,THERM

National Stock Number

FSC	FSG	NIIN	INC
8030	80	01-628-5010 / 016285010	18491

9530001

Sealing Compound

COLOR: CLEAR
CONTENT WITHIN EACH UNIT PACKAGE: CONSISTS OF 90 GRAM TUBE RESIN AND 45 GRAM TUBE HARDENER
MATERIAL: RESIN
QUANTITY WITHIN EACH UNIT PACKAGE: 135.000 GRAMS
RATED DRYING TIME: 1.000 HOURS MINIMUM AND 2.000 HOURS MAXIMUM
PHYSICAL FORM: PASTE
SPECIFIC USAGE DESIGN: FOR SEALING LEAKS IN VACUUM SYSTEMS AND COMPONENTS
SUPPLEMENTARY FEATURES: 135 GRAM KIT

Weight and Dimensions

National Stock Number

Box Weight	Box Size	Item Weight	Item Dimensions	FSC	FSG	NIIN	INC
--		--	--	8030	80	00-998-3321 / 009983321	03268

National Motor Freight / Schedule B

NMFC	Description	Schedule B
149980	PAINT AND RELATED MATERIALS	3214100010 / Caulking compounds

8030-01-365-3913

Sealing Compound

COLOR:	RED
FEATURES PROVIDED:	SEPARATE CATALYST
MATERIAL:	RUBBER SYNTHETIC
QUANTITY WITHIN EACH UNIT PACKAGE:	3.500 OUNCES
RATED DRYING TIME:	8.000 HOURS MAXIMUM
PHYSICAL FORM:	PASTE
SPECIAL FEATURES:	LOW ADHESION; POLYSULFIDE; 2 HOUR WORKING TIME
SPECIFIC USAGE DESIGN:	FOR AIRCRAFT ACCESS DOORS
SUPPLEMENTARY FEATURES:	3-1/2 OUNCE IN 6 OUNCE CARTRIDGE
VOLATILE ORGANIC COMPOUND IN GRAMS PER LITER:	225.0

Weight and Dimensions

Box Weight	Box Size	Item Weight	Item Dimensions
--	--	--	--

National Stock Number

FSC	FSG	NIIN	INC
8030	80	01-365-3913 / 013653913	03268

National Motor Freight / Schedule B

NMFC	Description	Schedule B
149980	PAINT AND RELATED MATERIALS	3214100010 / Caulking compounds

8010-00-302-5842

Primer Coating

COLOR: YELLOW
QUANTITY WITHIN EACH UNIT PACKAGE: 1.000 GALLONS
VEHICLE MATERIAL TYPE: EPOXY

National Stock Number

FSC	FSG	NIIN	INC
8010	80	00-302-5842 / 003025842	15705

8040-01-151-4258

Adhesive Primer

COLOR: COLORLESS
QUANTITY WITHIN EACH UNIT PACKAGE: 1.000 GALLONS
PHYSICAL FORM: LIQUID
SPECIAL FEATURES: ETHYL ACETATE SOLVENT BASE
SUPPLEMENTARY FEATURES: 1 GALLON CAN
USAGE DESIGN: FOR PROMOTING ADHESION OF POLYMERIC ELASTOMERS

Weight and Dimensions

National Stock Number

Box Weight	Box Size	Item Weight	Item Dimensions	FSC	FSG	NIIN	INC
--		--	--	8040	80	01-151-4258 / 011514258	23128

National Motor Freight / Schedule B

NMFC	Description	Schedule B
004630	ADHESIVES OR EPOXY RESINS	3814000000 / Organic composite solvents and thinners, not elsewhere specified or included; prepared paint or varnish removers

CW2A-462X0600

C-worthy Mount

CRITICALITY CODE JUSTIFICATION:

ZZZY

REFERENCE NUMBER DIFFERENTIATING CHARACTERISTICS:

MATERIAL WILL BE IN ACCORDANCE WITH NAVICP ACTIVITY HX QUALITY CONTROL, MANUFACTURING AND TESTING SPECIFICATIONS

Weight and Dimensions

National Stock Number

Box Weight	Box Size	Item Weight	Item Dimensions	FSC	FSG	NIIN	INC
--	--	--	--	2090	20	01-512-1545 / 015121545	7777

343617

Crew Door Telescoping Ar Ferrule

GENERAL CHARACTERISTICS ITEM DESCRIPTION:

STEEL MIL-S-6758,0.361 IN. MIN 0.363 IN. MAX DIA,0.400 IN. LG

Weight and Dimensions

National Stock Number

Box Weight	Box Size	Item Weight	Item Dimensions	FSC	FSG	NIIN	INC
.1lbs	--	--	--	1560	15	00-898-3787 / 008983787	7777

National Motor Freight / Schedule B

NMFC	Description	Schedule B
095190	HARDWARE,	8803300060 / Other parts of airplanes or helicopters for use in military aircraft (excludes propellers, rotors, undercarriages, and parts thereof)

6061T56G01

Exhaust Pipe

END ITEM IDENTIFICATION:

UH-60A HELICOPTER

SPECIAL FEATURES:

PIPE IS PART OF INFRARED SUPPRESSOR SYSTEM

Weight and Dimensions

National Stock Number

Box Weight	Box Size	Item Weight	Item Dimensions	FSC	FSG	NIIN	INC
73.5lbs	480 X 420 X 300	54.0lbs	410 X 310 X 200	1560	15	01-233-8332 / 012338332	60804

National Motor Freight / Schedule B

NMFC	Description	Schedule B
011790	AIRCRAFT PARTS	8803300060 / Other parts of airplanes or helicopters for use in military aircraft (excludes propellers, rotors, undercarriages, and parts thereof)

K000019-1001

Fuel Cell Kit

END ITEM IDENTIFICATION:

F-15 ACFT

GENERAL CHARACTERISTICS ITEM DESCRIPTION:

UNDER MS29513 HAS 84 PACKING PREFORM, UNDER ST7M424 HAS 9 GASKET,FUEL TAN, AND 68B580050-105 HAS 1 SEAL ASSEMBLY

Weight and Dimensions

National Stock Number

Box Weight	Box Size	Item Weight	Item Dimensions	FSC	FSG	NIIN	INC
A000.0lbs	9999 X 9999 X 9999	--	--	1560	15	01-034-4473 / 010344473	77777

National Motor Freight / Schedule B

NMFC	Description	Schedule B
095190	HARDWARE,	8803300060 / Other parts of airplanes or helicopters for use in military aircraft (excludes propellers, rotors, undercarriages, and parts thereof)

370939-5R

Duct Insulation Blanket

GENERAL CHARACTERISTICS ITEM DESCRIPTION: INSULATION,PREFORMED,TEMP RATED 570 DEG F,FABRICATION AND INST PER LAC DWG 351439 FSCM 98897

Weight and Dimensions

National Stock Number

Box Weight	Box Size	Item Weight	Item Dimensions	FSC	FSG	NIIN	INC
.3lbs	--	--	--	1560	15	00-614-6091 / 006146091	7777

National Motor Freight / Schedule B

NMFC	Description	Schedule B
103300	INSULATING MATERIAL SUB3	8803300060 / Other parts of airplanes or helicopters for use in military aircraft (excludes propellers, rotors, undercarriages, and parts thereof)

8739551

Tailcone Tip Assembly

END ITEM IDENTIFICATION:

ACFT MODEL F102

GENERAL CHARACTERISTICS ITEM DESCRIPTION:

AC/O FILLER 2 EA P/N 8-73955-15 AND P/N 8-73955-16, DOOR ASSY 2 EA P/N 8-73955-17 AND P/N 8-73955-18, DOUBLER ASSY 2 EA P/N 8-73955-19 AND P/N 8-73955-20, TIP 2 EA P/N 8-73955-21 AND P/N 8-73955-22

National Stock Number

FSC	FSG	NIIN	INC
1560	15	00-475-2930 / 004752930	7777

50552152

Small Arms-fr Supplemental Armor

END ITEM IDENTIFICATION:

USED ON C-130J HERCULES AIRCRAFT

SPECIAL FEATURES:

SPACER

National Stock Number

FSC	FSG	NIIN	INC
1560	15	01-501-9300 / 015019300	37077

70206-01003-043

Windshield Shim Kit

AIRFRAME STRUCTURAL COMPONENTS NATIONAL STOCK NUMBER 1560-01-443-4117 SHIM KIT,WINDSHIELD.

Weight and Dimensions

National Stock Number

Box Weight	Box Size	Item Weight	Item Dimensions	FSC	FSG	NIIN	INC
1.7lbs	--	--	--	1560	15	01-443-4117 / 014434117	77777

National Motor Freight / Schedule B

NMFC	Description	Schedule B
011790	AIRCRAFT PARTS	8803300060 / Other parts of airplanes or helicopters for use in military aircraft (excludes propellers, rotors, undercarriages, and parts thereof)

745571

Nonexpandable Shelter

DOOR QUANTITY: 1
ELECTRICALLY SHIELDED FEATURE: NOT INCLUDED
END ITEM IDENTIFICATION: 1905-01-154-1191
FLOOR MATERIAL: WOOD
OVERALL HEIGHT: 1.5 FEET NOMINAL
OVERALL LENGTH: 1.0 FEET NOMINAL
ROOF MATERIAL: WOOD
OVERALL WIDTH: 1.0 FEET NOMINAL
PART NAME ASSIGNED BY CONTROLLING AGENCY: INSTRUMENT SHELTER
SPECIAL FEATURES: SUGAR PINE WOOD, WEIGHT IS 10.19 LBS.
WALL MATERIAL: WOOD
WINDOW QUANTITY: 0
USAGE DESIGN: HOUSING

Weight and Dimensions

National Stock Number

Box Weight	Box Size	Item Weight	Item Dimensions	FSC	FSG	NIIN	INC
--		--	--	5411	54	01-615-9287 / 016159287	35191

60VRAD01TN

Shelter Radome

PREFABRICATED AND PORTABLE BUILDINGS NATIONAL STOCK NUMBER 5410-01-604-7383 SHELTER RADOME.

National Stock Number

FSC	FSG	NIIN	INC
5410	54	01-604-7383 / 016047383	77777

CCC-C-419

Duck Cloth

CLOTH WEIGHT: 23.900 OUNCES PER SQUARE YARD MINIMUM AND 26.300 OUNCES PER SQUARE YARD MAXIMUM
COLOR: NATURAL BOTH SIDES
FIBER MATERIAL: COTTON BASIC
NONDEFINITIVE SPEC/STD DATA: I TYPE
WIDTH: 42.000 INCHES NOMINAL
SURFACE CONDITION: MEDIUM
TRADE DESIGNATION: 4

National Motor Freight / Schedule B

National Stock Number

NMFC	Description	Schedule B	FSC	FSG	NIIN	INC
049265	CLOTH/FABRIC/PIECE GOODS		8305	83	00-185-8657 / 001858657	29971

S21-500-100

Valve Disk Filter

VALVES, POWERED NATIONAL STOCK NUMBER 4810-01-374-4358 FILTER,DISK,VALVE.

Weight and Dimensions

National Stock Number

Box Weight	Box Size	Item Weight	Item Dimensions	FSC	FSG	NIIN	INC
--	--	--	--	4810	48	01-374-4358 / 013744358	77777

National Motor Freight / Schedule B

NMFC	Description	Schedule B
051080	FAUCETS,BIBCOCKS,GATES VALVES	

P58719 converted into R431004661

Directional Control Linear Valve

END CONNECTION QUANTITY: 4
 CONNECTION TYPE: THREADED INTERNAL PIPE
 NOMINAL THREAD SIZE: 0.250 INCHES
 SPECIAL FEATURES: POT METAL BODY; FURNISHED WITH 2 THD PLUGS
 THREAD SERIES DESIGNATOR: NPT
 VALVE OPERATION METHOD: AIR

Weight and Dimensions

National Stock Number

Box Weight	Box Size	Item Weight	Item Dimensions	FSC	FSG	NIIN	INC
--	--	--	--	4810	48	00-431-6642 / 004316642	61929

National Motor Freight / Schedule B

NMFC	Description	Schedule B
133300	MACHINERY/MACHINES	8481809050 / Other taps, cocks, valves, etc.

02-355000

Flow Control Valve

END CONNECTION QUANTITY: 1
 CONNECTION TYPE: THREADED EXTERNAL PIPE
 CURRENT RATING IN AMPS: 0.7
 FLOW CONTROL DEVICE: POPPET
 PRESSURE CLASS: 4000.0 POUNDS PER SQUARE INCH
 SPECIAL FEATURES: ALSO NEED CARTRIDGESEAL KIT PART NUMBER 02 -154069, RATED FLOW 42 US GAL PER MIN, OPERATING TEMP MIN 22 DEG TO 194 DEG F,-HOUSING MATERIAL ALUM OR STEEL,COIL RESISTANCE @68 DEG F 25 OHMS, NOSE IN SIDE OUT, NORMALLY CLOSED, PRESSURE COMPENSATEDPOPPET TYPE SCREW IN CARTRIDGE
 VALVE OPERATION METHOD: SOLENOID
 VOLTAGE IN VOLTS AND CURRENT TYPE: 12.0 DC

Weight and Dimensions

National Stock Number

Box Weight	Box Size	Item Weight	Item Dimensions	FSC	FSG	NIIN	INC
2.6lbs		--	--	4810	48	01-479-5095 / 014795095	45506

National Motor Freight / Schedule B

NMFC	Description	Schedule B
127200	PRESSURE REDCNG WATER RELIEF VALVE	8481809015 / Regulator valves, self-operating, for controlling variables such as temperature, pressure, flow and liquid level

T9454

Globe Valve

BONNET ATTACHMENT METHOD:	THREADED
BONNET TYPE:	OUTSIDE SCREW-YOKE
CRITICALITY CODE JUSTIFICATION:	ZZZY
FLOW CONTROL DEVICE:	DISK
MATERIAL:	COPPER ALLOY OVERALL
NOMINAL THREAD SIZE:	0.500 INCHES 1ST END
REFERENCE NUMBER DIFFERENTIATING CHARACTERISTICS:	MATERIAL WILL BE IN ACCORDANCE WITH SHIPS PARTS CONTROL CENTER ACTIVITY HX QUALITY CONTROL,MANUFACTURING AND TESTING SPECIFICATIONS
THREAD SERIES DESIGNATOR:	NPT 1ST END

Weight and Dimensions

National Stock Number

Box Weight	Box Size	Item Weight	Item Dimensions	FSC	FSG	NIIN	INC
1.5lbs	50 X 35 X 35	--	--	4820	48	01-195-8074 / 011958074	05485

HV284233-1

Solenoid Valve

END ITEM IDENTIFICATION: LOS ANGELES CLASS SSN
MATERIAL: STEEL CORROSION RESISTING BODY
SPECIAL FEATURES: VALVE HAS THREE INTERNAL NPT THREADED PORTS. SOLENOID HAS TWO NON-POLARIZED TERMINALS WITH 6-32 UNC WIRE ATTACHMENT SCREW.
VALVE OPERATION METHOD: SOLENOID
VOLTAGE IN VOLTS AND CURRENT TYPE: 28.0 DC

Weight and Dimensions

National Stock Number

Box Weight	Box Size	Item Weight	Item Dimensions	FSC	FSG	NIIN	INC
--	--	--	--	4810	48	01-551-0571 / 015510571	10998

National Motor Freight / Schedule B

NMFC	Description	Schedule B
051080	FAUCETS,BIBCOCKS,GATES VALVES	

D1338430

Special Actuator Valve Diaphragm

END ITEM IDENTIFICATION: 4810-01-539-8588; NEW CONSTRUCTION LCS1
 MEDIA FOR WHICH DESIGNED: AIR
 III MATERIAL: RUBBER BUTADIENE-ACRYLONITRILE CLASS NBR AND PLASTIC POLYESTER
 SPECIAL FEATURES: NEXT HIGHER ASSEMBLY: 4810-01-539-8728, ACTUATOR SUBASSEMBLY; USED ON 4810-01-539-8689 ACTUATOR AND 4810-01-539-8588, VALVE AND ACTUATOR
 STYLE DESIGNATOR: SPECIAL SHAPED

Weight and Dimensions

National Stock Number

Box Weight	Box Size	Item Weight	Item Dimensions	FSC	FSG	NIIN	INC
--	--	--	--	4810	48	01-539-8870 / 015398870	40088

National Motor Freight / Schedule B

NMFC	Description	Schedule B
051080	FAUCETS,BIBCOCKS,GATES VALVES	8481909090 / Parts of taps, cocks, valves and similar appliances

1 1-2 CS790TT

Ball Valve

BONNET TYPE:	PACKING RETAINING
CONNECTION STYLE:	PLAIN,OPTIONAL END(PPIPE) ALL ENDS
CONNECTION TYPE:	THREADED INTERNAL PIPE ALL ENDS
FURNISHED ITEMS AND QUANTITY:	2 NUT AND 2 TAILPIECE
MATERIAL:	PLASTIC POLYTETRAFLUOROETHYLENE PACKING
MATERIAL:	PLASTIC POLYTETRAFLUOROETHYLENE SEAT
MATERIAL:	STEEL BODY
MAXIMUM OPERATING PRESSURE:	1500.0 POUNDS PER SQUARE INCH 1ST RESPONSE
MAXIMUM OPERATING TEMP:	366.0 DEG FAHRENHEIT 2ND RESPONSE
MEDIA FOR WHICH DESIGNED:	STEAM 2ND RESPONSE
MEDIA FOR WHICH DESIGNED:	WATER-OIL-GAS 1ST RESPONSE
NOMINAL THREAD SIZE:	1.500 INCHES ALL ENDS
STYLE DESIGNATOR:	STRAIGHT THRU
THREAD DIRECTION:	RIGHT-HAND ALL ENDS
THREAD SERIES DESIGNATOR:	NPT ALL ENDS
VALVE OPERATION METHOD:	MANUAL

Weight and Dimensions

National Stock Number

Box Weight	Box Size	Item Weight	Item Dimensions	FSC	FSG	NIIN	INC
--		--	--	4820	48	00-436-7884 / 004367884	20962

National Motor Freight / Schedule B

NMFC	Description	Schedule B
051080	FAUCETS,BIBCOCKS,GATES VALVES	8481803070 / Ball type taps, cocks and valves of steel, hand operated

D303407-025-0042.9

Push-pull Control Assembly

EFFECTIVE LENGTH: 45.090 INCHES NOMINAL

Weight and Dimensions

National Stock Number

Box Weight	Box Size	Item Weight	Item Dimensions	FSC	FSG	NIIN	INC
1.1lbs	--	--	--	2590	25	01-246-0948 / 012460948	07468

National Motor Freight / Schedule B

NMFC	Description	Schedule B
133300	MACHINERY/MACHINES	8412909080 / Parts of engines and motors

2608192-1

Brake Slack Adjuster

VEHICULAR BRAKE, STEERING, AXLE, WHEEL, AND TRACK COMPONENTS NATIONAL STOCK NUMBER 2530-01-272-2502 ADJUSTER,SLACK,BRAKE.

National Stock Number

FSC	FSG	NIIN	INC
2530	25	01-272-2502 / 012722502	10090

C16-29915B

Lever Action Shock Absorber

END ITEM IDENTIFICATION:

2320-01-549-8577 TRUCK,CARGO

PART NAME ASSIGNED BY CONTROLLING AGENCY:

DAMPER, CAB DOOR

Weight and Dimensions

National Stock Number

Box Weight	Box Size	Item Weight	Item Dimensions	FSC	FSG	NIIN	INC
--		--	--	2510	25	01-589-0359 / 015890359	18433

National Motor Freight / Schedule B

NMFC	Description	Schedule B
019500	AUTO SHOCK ABSORBERS R PARTS	

92-38

Lock

VEHICULAR BRAKE, STEERING, AXLE, WHEEL, AND TRACK COMPONENTS NATIONAL STOCK NUMBER 2530-00-145-8220 LOCK.

National Stock Number

FSC	FSG	NIIN	INC
2530	25	00-145-8220 / 001458220	77777

PDD8517

Arm

MISCELLANEOUS VEHICULAR COMPONENTS NATIONAL STOCK NUMBER 2590-01-301-0954 ARM.

Weight and Dimensions

National Stock Number

Box Weight	Box Size	Item Weight	Item Dimensions	FSC	FSG	NIIN	INC
20.3lbs	--	--	--	2590	25	01-301-0954 / 013010954	77777

National Motor Freight / Schedule B

NMFC	Description	Schedule B
133300	MACHINERY/MACHINES	

12450078

Gun Mount Pedestal

UNABLE TO DECODE:

UNABLE TO DECODE

Weight and Dimensions

National Stock Number

Box Weight	Box Size	Item Weight	Item Dimensions	FSC	FSG	NIIN	INC
38.0lbs	--	--	--	1005	10	01-457-5812 / 014575812	23724

National Motor Freight / Schedule B

NMFC	Description	Schedule B
069300	FIREARMS/PARTS IN BOXES	9305996600 / Part and accessories of articles of headings 9301 to 9304

7012757

Shaft Assembly Worm

GENERAL CHARACTERISTICS ITEM DESCRIPTION:

ITEM CONSISTS OF BLOCK P/N 7012754; BUSHING P/N 7012750; SCREW P/N 7012755

Weight and Dimensions

National Stock Number

Box Weight	Box Size	Item Weight	Item Dimensions	FSC	FSG	NIIN	INC
.6lbs	--	--	--	1005	10	00-701-2757 / 007012757	7777

National Motor Freight / Schedule B

NMFC	Description	Schedule B
194120	WASHERS/GASKETS/PCKG DVCS	9305996600 / Part and accessories of articles of headings 9301 to 9304

S205129-101

Ammunition Chute Assembly

END ITEM IDENTIFICATION:

20MM LALS II,NIMITZ CLASS CVN.

Weight and Dimensions

National Stock Number

Box Weight	Box Size	Item Weight	Item Dimensions	FSC	FSG	NIIN	INC
16.5lbs	--	--	--	1005	10	01-450-2517 / 014502517	38116

National Motor Freight / Schedule B

NMFC	Description	Schedule B
069300	FIREARMS/PARTS IN BOXES	9305911000 / Parts and accessories for military rifles of heading 9301

3269533

Manual Trigger Plate

END ITEM IDENTIFICATION:

MACHINE GUN,40 MM. GRENADE(MK 19); NSN 1010-01-126-9063

GENERAL CHARACTERISTICS ITEM DESCRIPTION:

STEEL,AISI 1010-1025; PHOSPHATE COAT PER DOD-P-16232,TYPE M,CLASS 2

Weight and Dimensions

National Stock Number

Box Weight	Box Size	Item Weight	Item Dimensions	FSC	FSG	NIIN	INC
--	60 X 60 X 20	.4lbs	50 X 50 X 10	1010	10	01-129-1234 / 011291234	77777

National Motor Freight / Schedule B

NMFC	Description	Schedule B
146230	GUNS MACHINE/PARTS SM ARMS AMMO	9305996600 / Part and accessories of articles of headings 9301 to 9304

LMP360

Grenade Launcher Barrel

END ITEM IDENTIFICATION: LAUNCHER,GRENADE,40MM M203
SIZE DESIGNATION: 40 MILLIMETER
OVERALL LENGTH: 13.902 INCHES NOMINAL

Weight and Dimensions

National Stock Number

Box Weight	Box Size	Item Weight	Item Dimensions	FSC	FSG	NIIN	INC
--	--	--	--	1010	10	01-376-3342 / 013763342	21719

National Motor Freight / Schedule B

NMFC	Description	Schedule B
091720	GUN BARRELS STEEL IN BOXES	9305996600 / Part and accessories of articles of headings 9301 to 9304

1080-01-475-0696

Radar Scat Camouflage Net System

END ITEM IDENTIFICATION:

ULTRAWEIGHT CAMOUFLAGE NET SYSTEMAN/USQ-159

Weight and Dimensions

National Stock Number

Box Weight	Box Size	Item Weight	Item Dimensions	FSC	FSG	NIIN	INC
70.0lbs	500 X 225 X 115	97.0lbs	495 X 220 X 110	1080	10	01-475-0696 / 014750696	66968

National Motor Freight / Schedule B

NMFC	Description	Schedule B
147140	OUTFITS CAMOUFLAGE NET MILITARY	6307909995 / Made-up articles of textile material

